

CATÁLOGO PVC

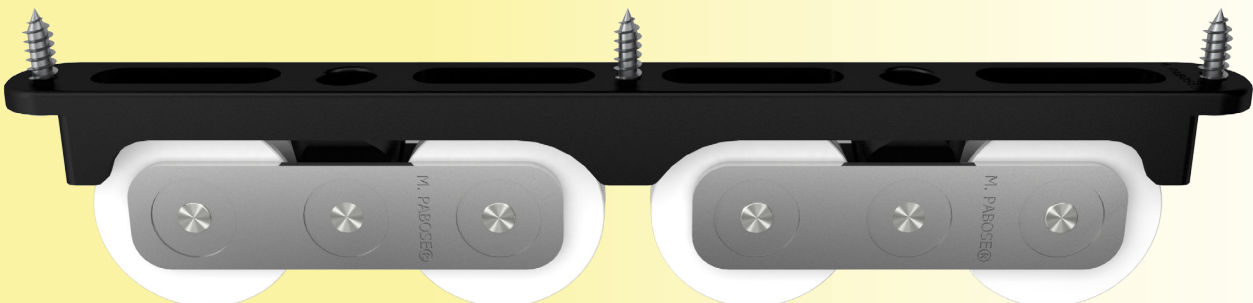

FABRICANTE DE HERRAJES
PARA CARPINTERÍA DE ALUMINIO,
PVC, CRISTAL Y MADERA

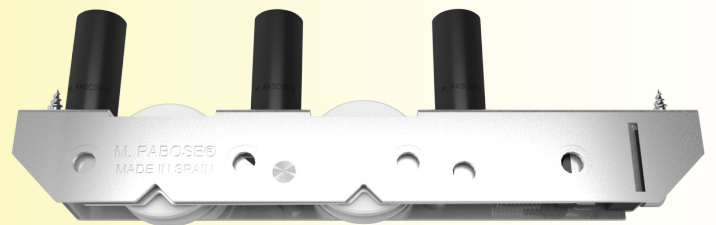
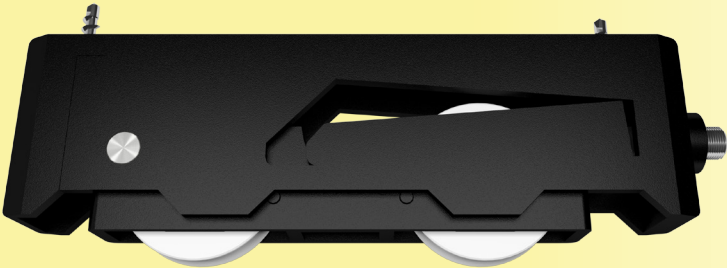

Referencia	Extrusor/Cliente	Serie	Perfil	Rueda radio/ang.	Tipo de Conjunto	Tipo de Rodamiento	Soporte	Carga (Kg)	
								Rueda	Hoja
P-2000F-A		Varias		2,25	Fijo Simple	Agujas	Zamak ZL5 Pintado Negro	80	160

Cajetin 15,5 x 53,5 mm.

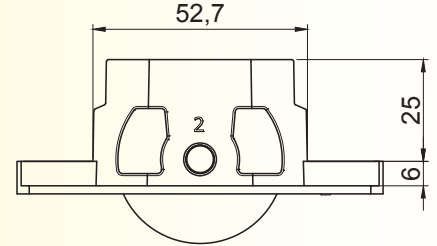
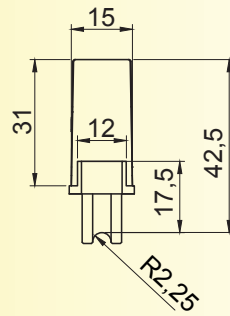

TP-2000-A		Varias		2,25	Tándem Fijo Basculante	Agujas	Zamak ZL5 Pintado Negro Tirantes INOX.	80	320
------------------	--	--------	--	------	---------------------------	--------	--	----	-----

Cajetin 15,5 x 115 mm.

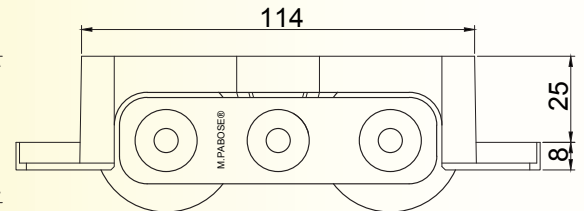
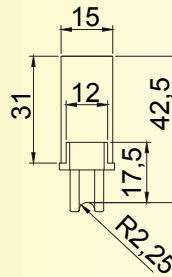

P-2000F-EKS-A	Azembra	Calafate	Hoja: ROY-1902 Marco: ROY-1901	2,25	Fijo Simple	Agujas	Zamak ZL5 Pintado Negro	80	160
			c/ Suplemento 5 mm.						

Cajetin 15,5 x 53,5 mm.

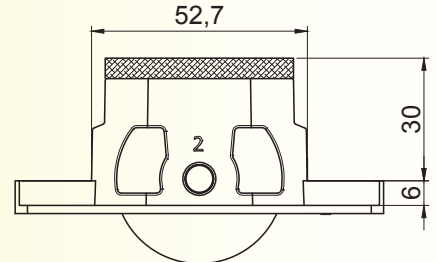
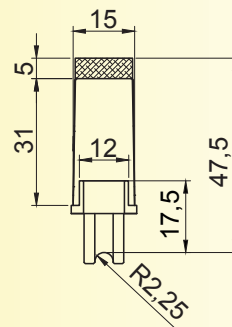

TP-2000-EKS-A	Azembra	Calafate	Hoja: ROY-1902 Marco: ROY-1901	2,25	Tándem Fijo Basculante	Agujas	Zamak ZL5 Pintado Negro Tirantes INOX	80	320
			c/ 2 Suplementos 5 mm.						

Cajetin 15,5 x 115 mm.

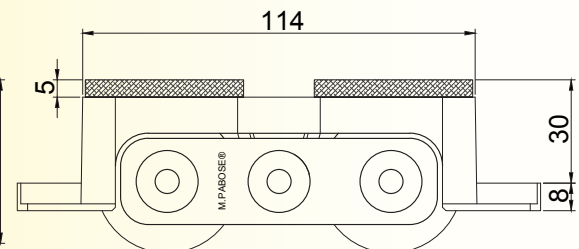
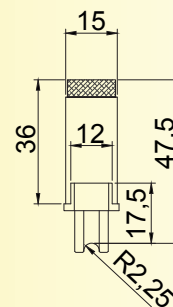

"Los suplementos de poliamida se suministran en bolsa aparte"

M. Pabose® como fabricante del producto se reserva el derecho de efectuar sin previo aviso, las modificaciones que considere oportunas para mejorar las prestaciones de sus productos.

Referencia	Extrusor/Cliente	Serie	Perfil	Rueda	Tipo de	Soporte	Carga (Kg)		
				radio/ang.			Conjunto	Rodamiento	Rueda
P-2001F-A		Varias		2,75	Fijo Simple	Agujas	Zamak ZL5 Pintado negro	90	180

Cajetin 15,5 x 53,5 mm.

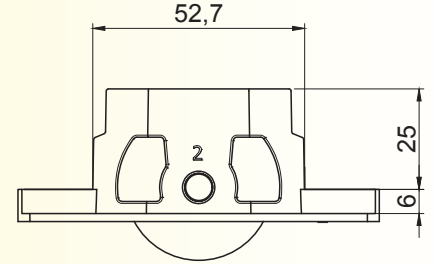
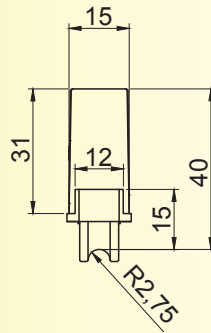

TP-2001-A		Varias		2,75	Tándem Fijo Basculante	Agujas	Zamak ZL5 Pintado Negro Tirantes INOX.	90	360
------------------	--	--------	--	------	---------------------------	--------	--	----	-----

Cajetin 15,5 x 115 mm.

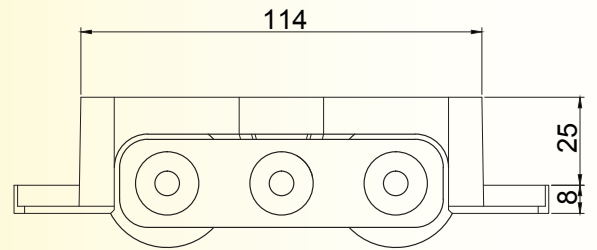
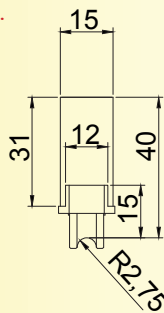

P-2001F-M-A	Rehau	Serie 781	Hoja: 614.883 Marco:609.363 Marco:614.823 Marco:637.989	2,50	Fijo Simple	Agujas	Zamak ZL5 Pintado negro	90	180
	Kömmerling								

Cajetin 15,5 x 53,5 mm.

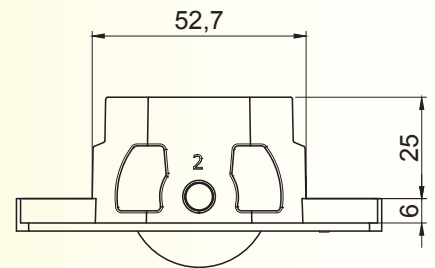
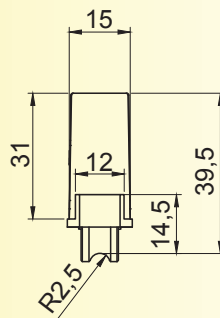
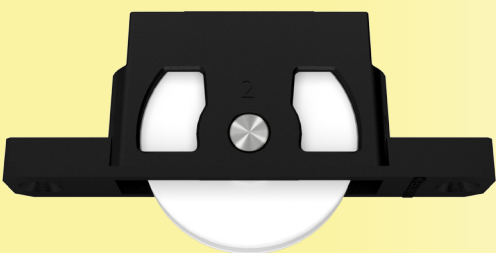

TP-2001-M-A		Igual a la P-2001F-M-A		2,50	Tándem Fijo Basculante	Agujas	Zamak ZL5 Pintado Negro Tirantes INOX.	90	360
--------------------	--	------------------------	--	------	---------------------------	--------	--	----	-----

Cajetin 15,5 x 115 mm.

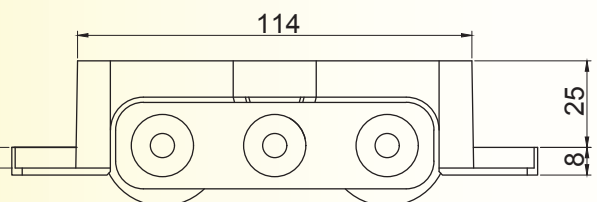
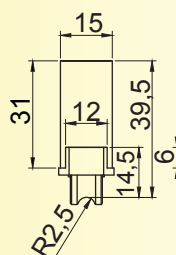

“Los suplementos de poliamida se suministran en bolsa aparte”

M. Pabose® como fabricante del producto se reserva el derecho de efectuar sin previo aviso, las modificaciones que considere oportunas para mejorar las prestaciones de sus productos.

Referencia	Extrusor/Cliente	Serie	Perfil	Rueda radio/ang.	Tipo de Conjunto	Rodamiento	Soporte	Carga (Kg)	
								Rueda	Hoja
P-2001F-KMM-A		Varias		2,25	Fijo Simple	Agujas	Zamak ZL5 Pintado Negro	80	160

Cajetin 15,5 x 53,5 mm.

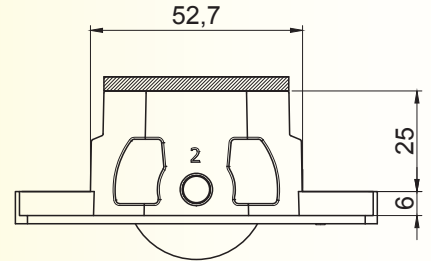
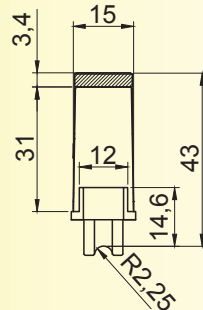

TP-2001-KMM-A		Varias		2,25	Tándem Fijo Basculante	Agujas	Zamak ZL5 Pintado Negro Tirantes INOX.	80	320

Cajetin 15,5 x 115 mm.

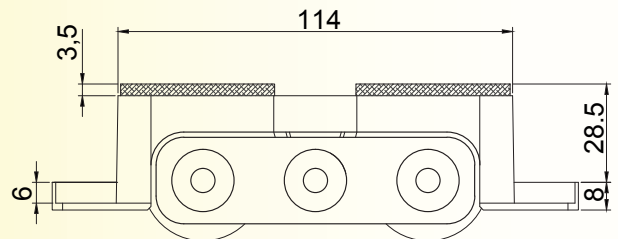
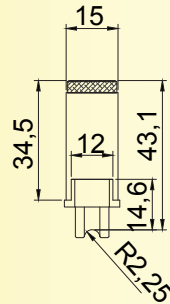

P-2001E-S01-A	Schüco	Corona S-74	Hoja: 8.857 Riel: 8.856	2,75	Fijo Simple	Agujas	Zamak ZL5 Pintado Negro	90	180

Cajetin 15,5 x 47,5 mm.

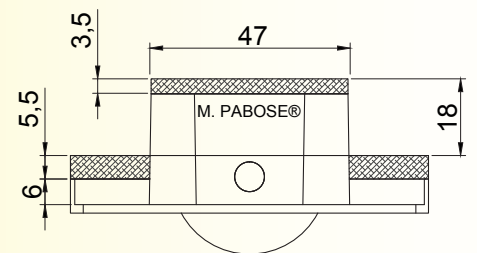
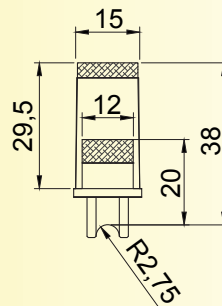
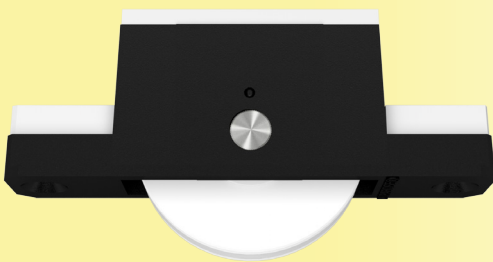

TP-2001E-S01-A	Schüco	Corona S-74	Hoja: 8.857 Riel: 8.856	2,50	Tándem Fijo Basculante	Agujas	Zamak ZL5 Pintado Negro Tirantes INOX.	90	360

Cajetin 15,5 x 115mm.

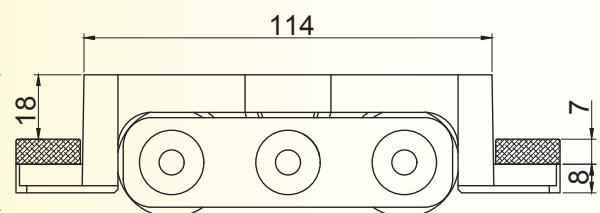
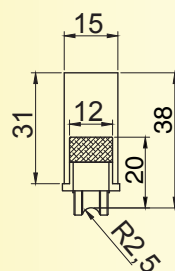

"Los suplementos de poliamida se suministran en bolsa aparte"

M. Pabose® como fabricante del producto se reserva el derecho de efectuar sin previo aviso, las modificaciones que considere oportunas para mejorar las prestaciones de sus productos.

Referencia	Extrusor/Cliente	Serie	Perfil	Rueda radio/ang.	Tipo de Conjunto	Rodamiento	Soporte	Carga (Kg)	
								Rueda	Hoja
P-2001E-S02-A	Gealan		Hoja: 3083-62 Hoja: 3083-63 Marco:3029x24	2,50	Fijo Simple	Agujas	Zamak ZL5 Pintado Negro	90	180

Cajetin 15,5 x 47,5 mm.

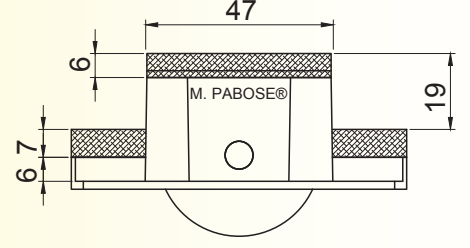
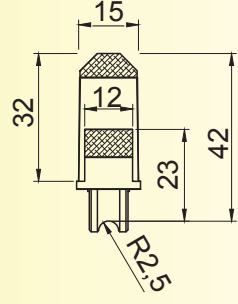
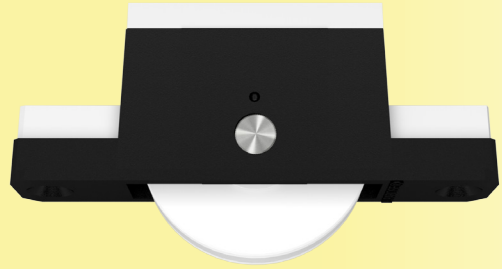

TP-2001E-S02-A	Gealan		Hoja: 3083-62 Hoja: 3083-63 Marco:3029x24	2,50	Tándem Fijo Basculante	Agujas	Zamak ZL5 Pintado Negro Tirantes INOX.	90	360

Cajetin 15,5 x 115mm.

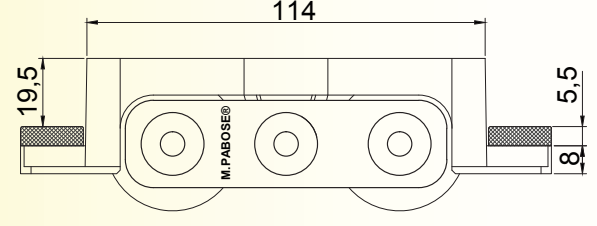
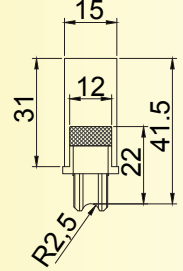

P-2001E-S03-A	Kömmerling	SF2-A	Hoja: P1386 Marco: P0385 Marco: P0386 Marco: P0387 Marco: P1998	2,50	Fijo Simple	Agujas	Zamak ZL5 Pintado Negro	90	180

Cajetin 15,5 x 47,5 mm.

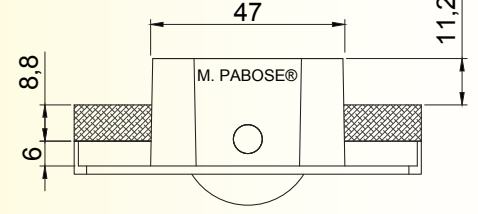
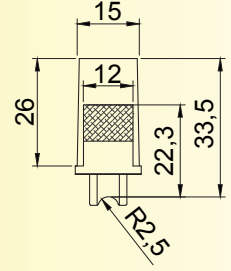
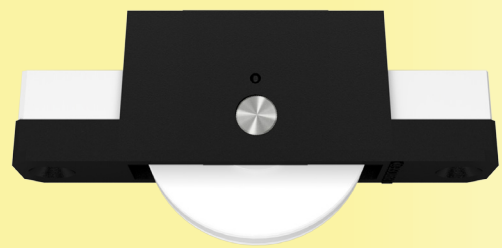

“Los suplementos de poliamida se suministran en bolsa aparte”

M. Pabose® como fabricante del producto se reserva el derecho de efectuar sin previo aviso, las modificaciones que considere oportunas para mejorar las prestaciones de sus productos.

Referencia	Extrusor/Cliente	Serie	Perfil	Rueda radio/ang.	Tipo de		Soporte	Carga (Kg)	
					Conjunto	Rodamiento		Rueda	Hoja
P-2001E-S04-A	Aluplast	SF-73	Hoja: 100x82 Marco:100.080	2,50	Fijo Simple	Agujas	Zamak ZL5 Pintado Negro	90	180

Cajetin 15,5 x 47,5 mm.

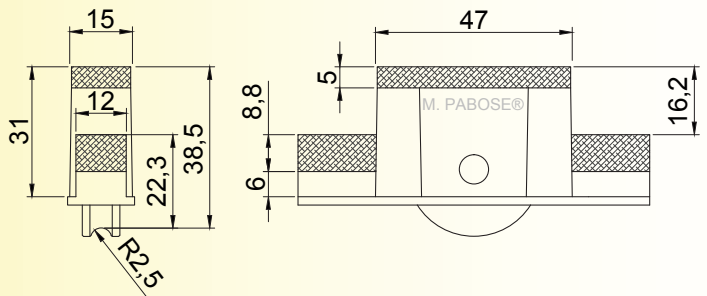
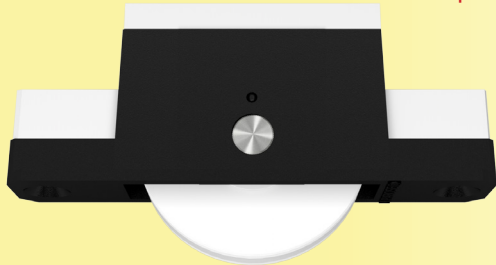

TP-2001E-S04-A	Aluplast	SF-73	Hoja: 100x82 Marco:100.080	2,50	Tándem Fijo Basculante	Agujas	Zamak ZL5 Pintado Negro Tirantes INOX	90	360

Cajetin 15,5 x 115 mm.

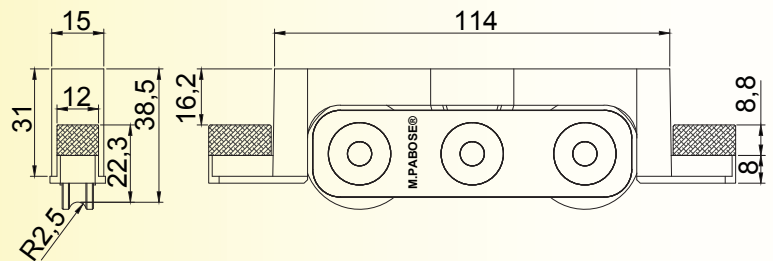

P-2001E-S05-A	Rehau	S-717	Hoja: 557.141 Marco:557.000	2,75	Fijo Simple	Agujas	Zamak ZL5 Pintado Negro	90	180

Cajetin 15,5 x 47,5 mm.

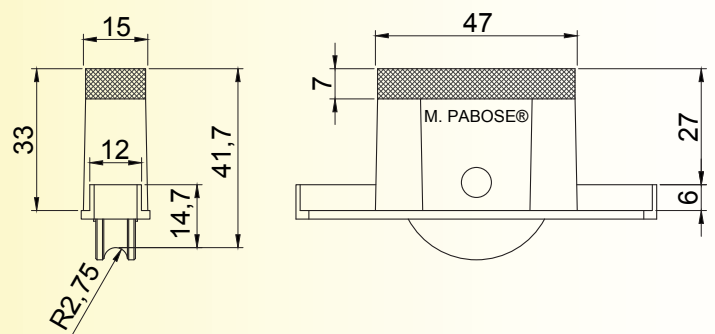
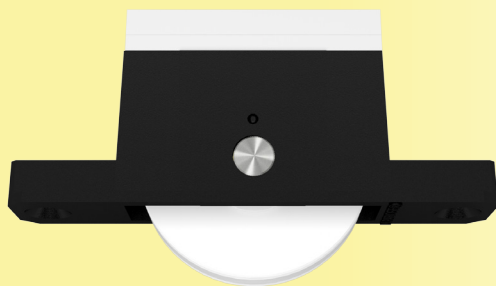

TP-2001E-S05-A	Rehau	S-717	Hoja: 557.141 Marco:557.000	2,50	Tándem Fijo Basculante	Agujas	Zamak ZL5 Pintado Negro Tirantes INOX	90	360

Cajetin 15,5 x 115 mm.

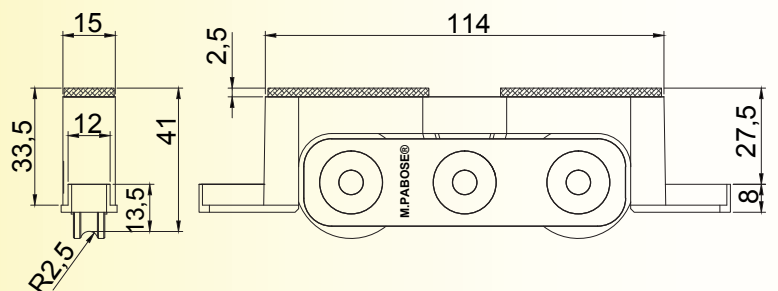

"Los suplementos de poliamida se suministran en bolsa aparte"

M. Pabose® como fabricante del producto se reserva el derecho de efectuar sin previo aviso, las modificaciones que considere oportunas para mejorar las prestaciones de sus productos.

Referencia	Extrusor/Cliente	Serie	Perfil	Rueda radio/ang.	Tipo de Conjunto	Rodamiento	Soporte	Carga (Kg)	
								Rueda	Hoja
P-2001E-S06-A	Veka	Ekosol-70	Hoja: 105.322 Marco: 105.351	2,50	Fijo Simple	Agujas	Zamak ZL5 Pintado negro	90	180
		Nova Ekosol CR-70							
c/ 2 Suplementos Lat. 5,5 mm									

Cajetin 15,5 x 47,5 mm.

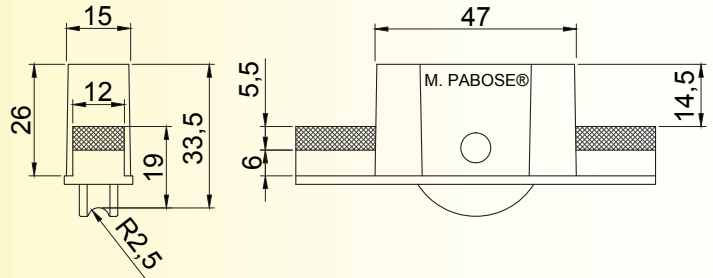
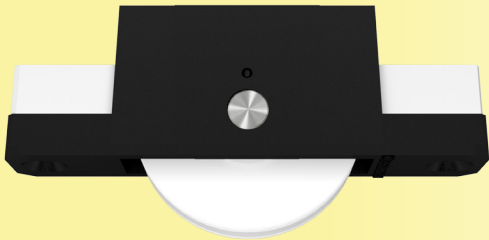

P-2001E-S07-A	Dimex	System Perfectt 70 mm.	Hoja: 611.000 Marco: 610.900	2,25	Fijo Simple	Agujas	Zamak ZL5 Pintado negro	80	160
	Aluplast	Multi slinding 96	Hoja: 100093 Marco: 100097						
c/ Suplemento 2,5 mm + 2 Suplementos Lat. 5,5 mm									

Cajetin 15,5 x 47,5 mm.

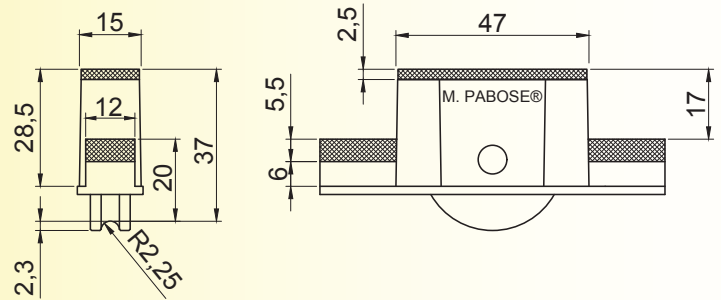
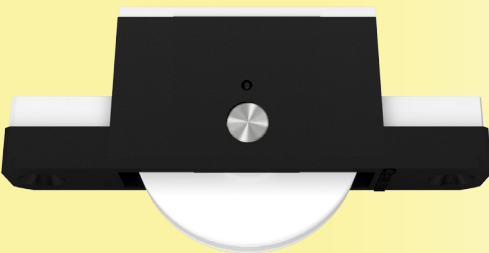

TP-2001E-S07-A	Dimex	System Perfectt 70 mm.	Hoja: 611.000 Marco: 610.900	2,50	Tándem Fijo Basculante	Agujas	Zamak ZL5 Pintado Negro Tirantes INOX	90	360
	Aluplast	Multi slinding 96	Hoja: 100093 Marco: 100097						
c/ 2 Suplementos Lat. 8 mm									

Cajetin 15,5 x 115 mm.

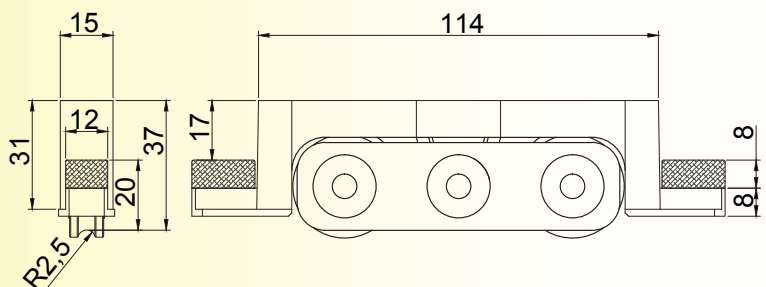

"Los suplementos de poliamida se suministran en bolsa aparte"

M. Pabose® como fabricante del producto se reserva el derecho de efectuar sin previo aviso, las modificaciones que considere oportunas para mejorar las prestaciones de sus productos.

Referencia	Extrusor/Cliente	Serie	Perfil	Rueda radio/ang.	Tipo de		Soporte	Carga (Kg)	
					Conjunto	Rodamiento		Rueda	Hoja
P-2001E-S08-A	Salamander	Inline SF	Hoja: 641.028 Marco: 640.028	2,50	Fijo Simple	Agujas	Zamak ZL5 Pintado negro	90	180

Cajetin 15,5 x 47,5 mm.

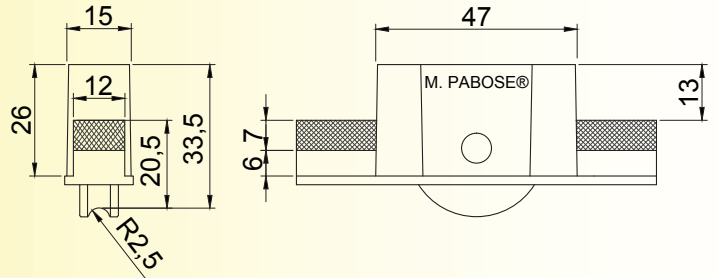
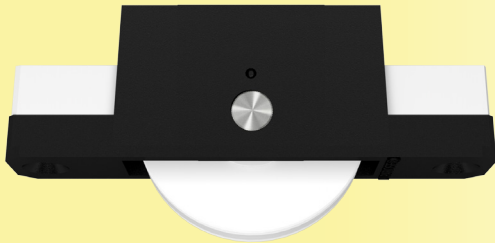

P-2001E-S09-A	Kömmerling	Orta	Hoja: P1683 Marco: P1661 Marco: P1667 Marco: P1673 Marco: P1678	2,25	Fijo Simple	Agujas	Zamak ZL5 Pintado Negro	80	160

Cajetin 15,5 x 47,5 mm.

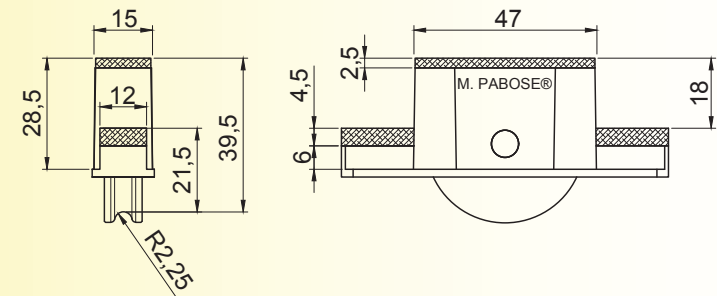
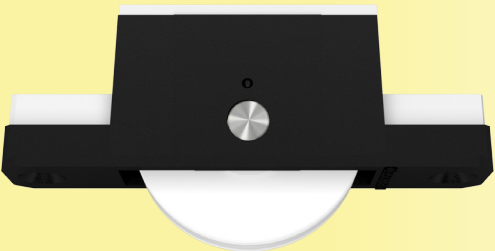

TP-2001E-S09-A	Kömmerling	Orta	Hoja: P1683 Marco: P1661 Marco: P1667 Marco: P1673 Marco: P1678	2,50	Tándem Fijo Basculante	Agujas	Zamak ZL5 Pintado Negro Tirantes INOX	90	360

Cajetin 15,5 x 115 mm.

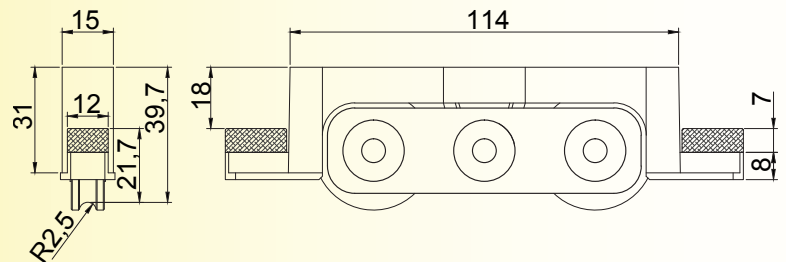

"Los suplementos de poliamida se suministran en bolsa aparte"

M. Pabose® como fabricante del producto se reserva el derecho de efectuar sin previo aviso, las modificaciones que considere oportunas para mejorar las prestaciones de sus productos.

Referencia	Extrusor/Cliente	Serie	Perfil	Rueda radio/ang.	Tipo de Conjunto	Rodamiento	Soporte	Carga (Kg)	
								Rueda	Hoja

P-2001E-S10-A	Gealan		Hoja: 3031-68 Hoja: 3031-69 Marco: 3030	2,50	Fijo Simple	Agujas	Zamak ZL5 Pintado Negro	90	180
			c/ Suplemento 6 mm + 2 Suplementos Lat. 7 mm						

Cajetin 15,5 x 47,5 mm.

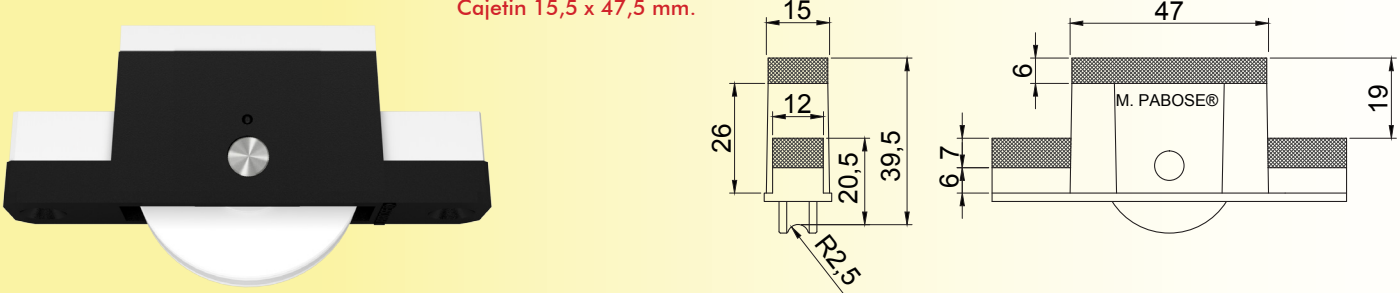

TP-2001E-S10-A	Gealan		Hoja: 3031-68 Hoja: 3031-69 Marco: 3030	2,50	Tándem Fijo Basculante	Agujas	Zamak ZL5 Pintado Negro Tirantes INOX	90	360
			c/ 2 Suplementos Lat. 5,5 mm.						

Cajetin 15,5 x 115 mm.

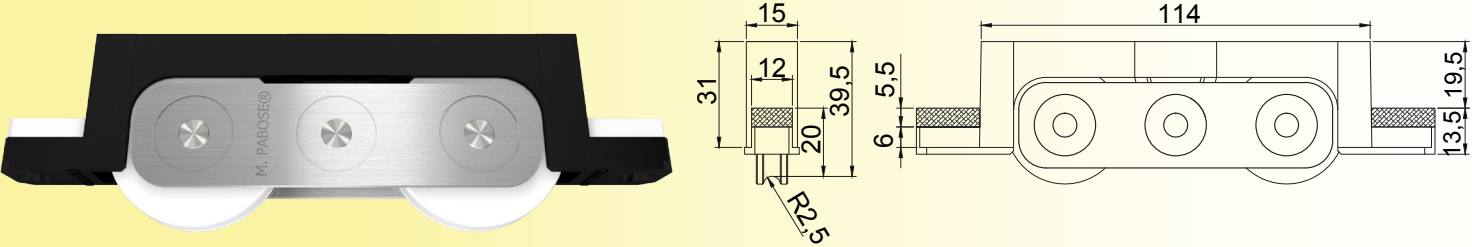

P-2001E-S11-A	Salamander	Hoja Grande		2,50	Fijo Simple	Agujas	Zamak ZL5 Pintado Negro	90	180

Cajetin 15,5 x 47,5 mm.

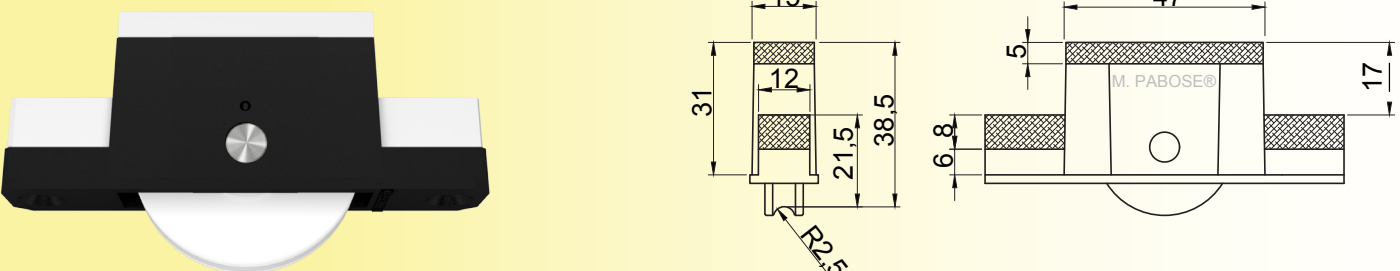

TP-2001E-S11-A	Salamander	Hoja Grande		2,50	Tándem Fijo Basculante	Agujas	Zamak ZL5 Pintado Negro Tirantes INOX	90	360

Cajetin 15,5 x 115 mm.

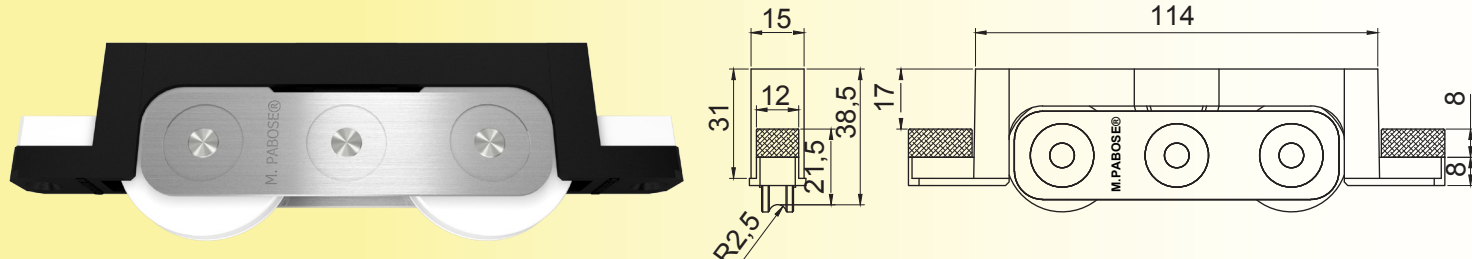

“Los suplementos de poliamida se suministran en bolsa aparte”

M. Pabose® como fabricante del producto se reserva el derecho de efectuar sin previo aviso, las modificaciones que considere oportunas para mejorar las prestaciones de sus productos.

Referencia	Extrusor/Cliente	Serie	Perfil	Rueda radio/ang.	Tipo de Conjunto	Tipo de Rodamiento	Soporte	Carga (Kg)	
								Rueda	Hoja
P-2001E-S12-A	Schüco		Hoja:8830	2,50	Fijo Simple	Agujas	Zamak ZL5 Pintado Negro	90	180

Cajetín 15,5 x 47,5 mm.

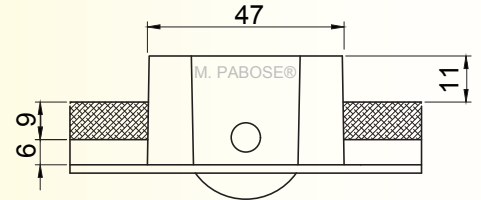
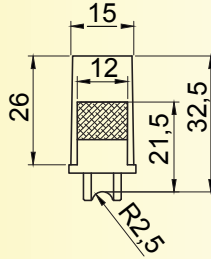
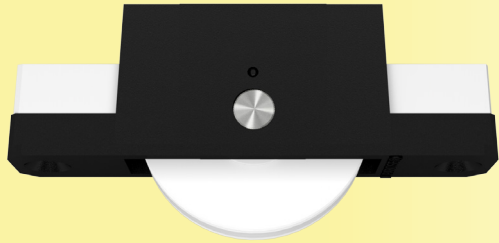

P-2001E-M-A	Azembla	Calafate	Hoja:ROY-1911 Marco:ROY-1901	2,50	Fijo Simple	Agujas	Zamak ZL5 Pintado Negro	90	180
--------------------	---------	----------	---------------------------------	------	-------------	--------	----------------------------	----	-----

Cajetín 15,5 x 47,5 mm.

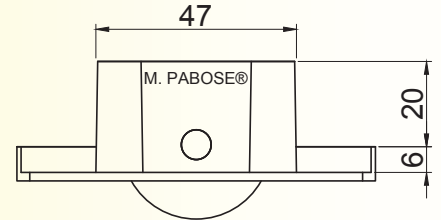
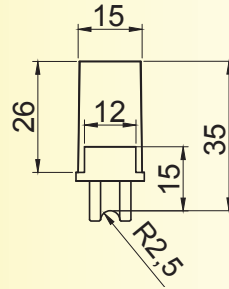
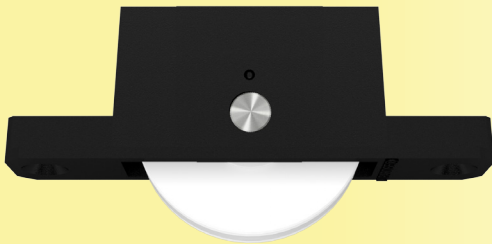

P-2001E-DC-A	Deceuninck	Tecnocor II	Hoja: 3.465 Marco: 3.450	2,25	Fijo Simple	Agujas	Zamak ZL5 Pintado Negro	80	160
---------------------	------------	-------------	-----------------------------	------	-------------	--------	----------------------------	----	-----

c/ Suplemento 3,5 mm.

Cajetín 15,5 x 47,5 mm.

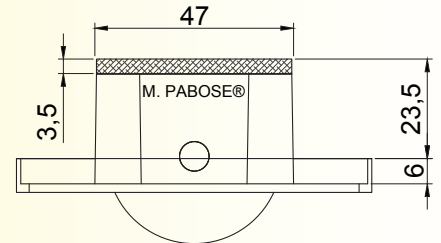
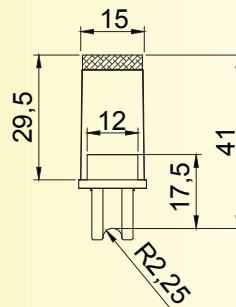
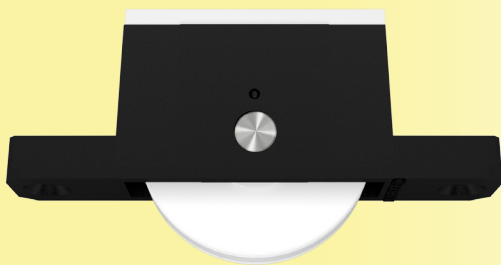

TP-2001E-DC-A	Deceuninck	Tecnocor II	Hoja: 3.465 Marco: 3.450	2,50	Tándem Fijo Basculante	Agujas	Zamak ZL5 Pintado Negro Tirantes INOX	90	360
----------------------	------------	-------------	-----------------------------	------	---------------------------	--------	---	----	-----

c/ 2 Suplementos 2,5mm + 2 Suplementos Lat. 3,5 mm

Cajetín 15,5 x 115 mm.

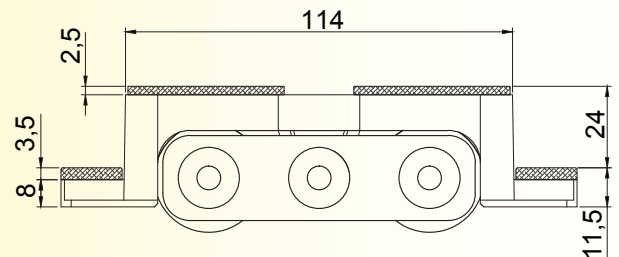
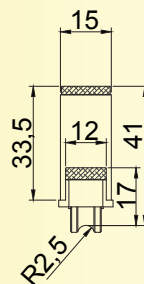

"Los suplementos de poliamida se suministran en bolsa aparte"

M. Pabose® como fabricante del producto se reserva el derecho de efectuar sin previo aviso, las modificaciones que considere oportunas para mejorar las prestaciones de sus productos.

Referencia	Extrusor/Cliente	Serie	Perfil	Rueda radio/ang.	Tipo de Conjunto	Rodamiento	Soporte	Carga (Kg)		
								Rueda	Hoja	
P-2003F-S02-A	Kömmerling	PremiLine	Hoja: 6.041	2,25	Fijo Simple	Agujas	Zamak ZL5 Pintado Negro	80	160	
			Marco: 6.050							
			Marco: 6.051							
			Marco: 6.052							
			Marco: 6.054							
c/ Suplemento 2,5 mm + 2 Suplementos Lat. 4,5 mm										

Cajetin 15,5 x 53,5 mm.

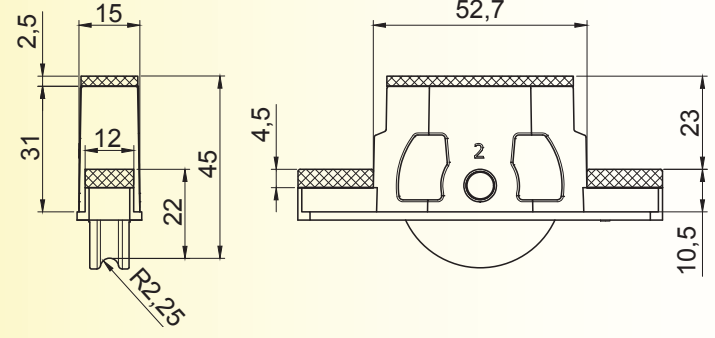

TP-2003-S02-A	Igual a la P-2003F-S02-A			2,25	Tándem Fijo Basculante	Agujas	Zamak ZL5 Pintado Negro Tirantes INOX	80	320
	c/ 2 Suplementos 2,5 mm + 2 Suplementos Lat. 4,5 mm								

Cajetin 15,5 x 115 mm.

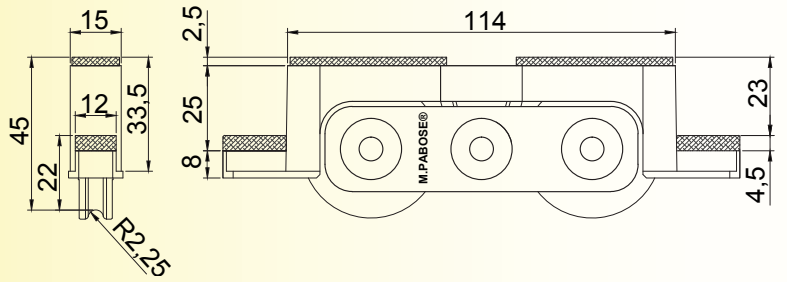

P-2003F-S04-A	Archicentro		Hoja: 88	2,50	Fijo Simple	Agujas	Zamak ZL5 Pintado Negro	90	180
	c/ Suplemento 8 mm								

Cajetin 15,5 x 53,5 mm.

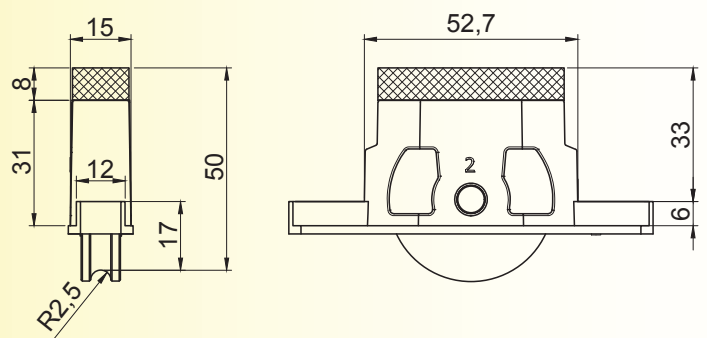

TP-2003-S04-A	Archicentro		Hoja: 88	2,50	Tándem Fijo Basculante	Agujas	Zamak ZL5 Pintado Negro Tirantes INOX	90	360
	c/ 2 Suplementos 8 mm.								

Cajetin 15,5 x 115 mm.

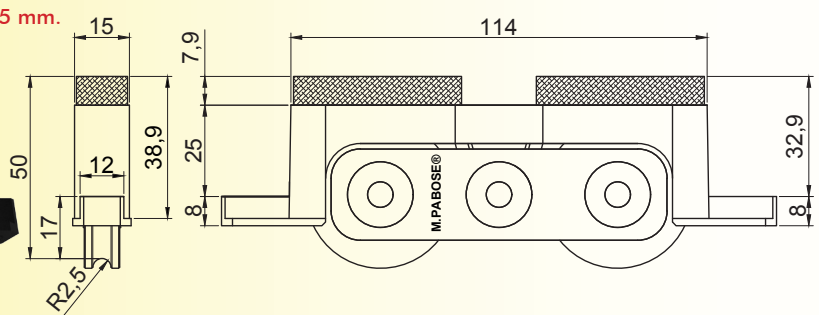

"Los suplementos de poliamida se suministran en bolsa aparte"

M. Pabose® como fabricante del producto se reserva el derecho de efectuar sin previo aviso, las modificaciones que considere oportunas para mejorar las prestaciones de sus productos.

Referencia	Extrusor/Cliente	Serie	Perfil	Rueda radio/ang.	Tipo de Conjunto	Tipo de Rodamiento	Soporte	Carga (Kg)	
								Rueda	Hoja
P-2003F-S05-A	Ventanales			2,25	Fijo Simple	Agujas	Zamak ZL5 Pintado Negro	80	160
	c/ Suplemento 7 mm.								

Cajetin 15,5 x 53,5 mm.

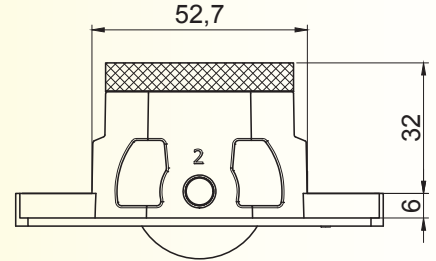
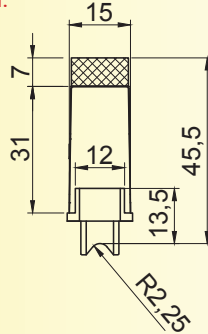

TP-2003-S05-A	Ventanales			2,25	Tándem Fijo Basculante	Agujas	Zamak ZL5 Pintado Negro Tirantes INOX	80	320
	c/ 2 Suplementos 7 mm								

Cajetin 15,5 x 115 mm.

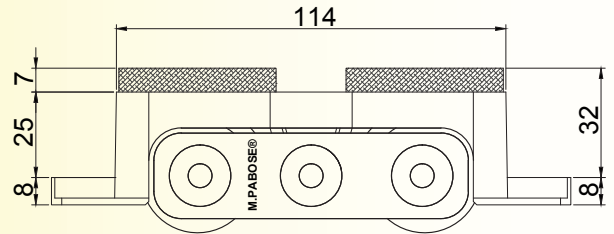
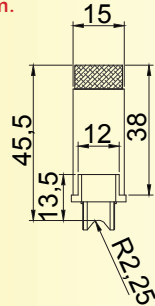

P-2003F-S06-A	Varias			2,25	Fijo Simple	Agujas	Zamak ZL5 Pintado Negro	80	160
	c/ Suplemento 5 mm + 2 Suplementos Lat. 4,5 mm								

Cajetin 15,5 x 53,5 mm.

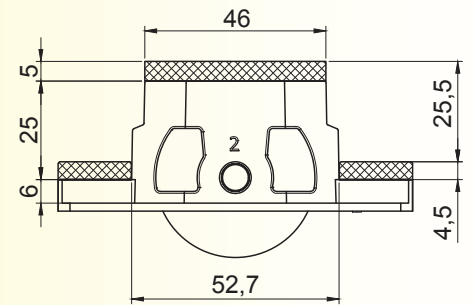
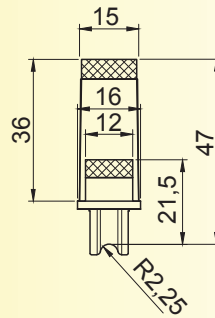
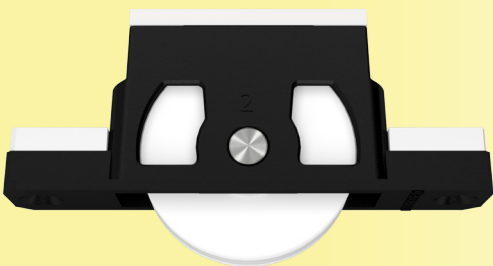

TP-2003-S06-A	Varias			2,25	Tándem Fijo Basculante	Agujas	Zamak ZL5 Pintado Negro Tirantes INOX	80	320
	c/ 2 Suplementos 5 mm + 2 Suplementos Lat. 4,5 mm								

Cajetin 15,5 x 115 mm.

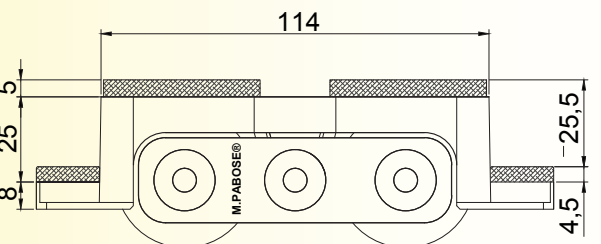
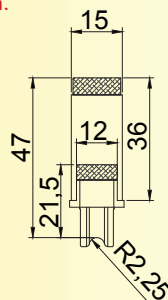

"Los suplementos de poliamida se suministran en bolsa aparte"

M. Pabose® como fabricante del producto se reserva el derecho de efectuar sin previo aviso, las modificaciones que considere oportunas para mejorar las prestaciones de sus productos.

Referencia	Extrusor/Cliente	Serie	Perfil	Rueda	Tipo de		Carga (Kg)		
				radio/ang.	Conjunto	Rodamiento	Soporte	Rueda	Hoja
P-2003F-S07-A	Deceuninck	Monorail Zendow	Hoja: 3.410 Marco: 3.400	2,50	Fijo Simple	Agujas	Zamak ZL5 Pintado Negro	90	180
	Royal Group	Sistema DC 62mm	Hoja:ROY-1404 Marco:ROY-1401 Marco:ROY-1402						
c/ Suplemento 7 mm + 2 Suplementos Lat. 4,5 mm									

Cajetin 15,5 x 53,5 mm.

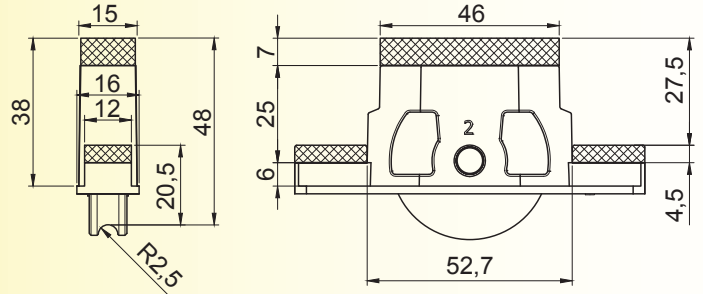

TP-2003-S07-A	Igual a la P-2003F-S07-A			2,50	Tándem Fijo Basculante	Agujas	Zamak ZL5 Pintado Negro Tirantes INOX	90	360
c/ 2 Suplementos 7 mm + 2 Suplementos Lat. 4,5 mm									

Cajetin 15,5 x 115 mm.

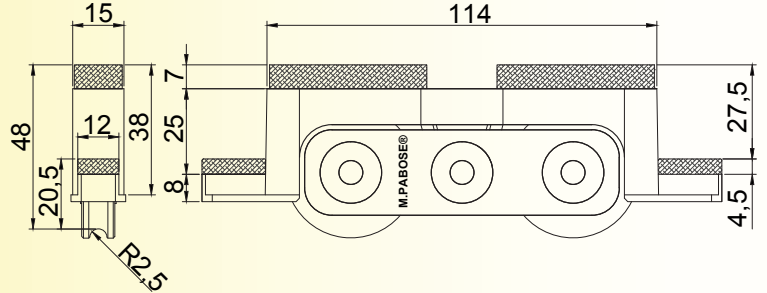

P-2003F-S08-A	Kömmerling	SF2-Asia	Hoja:1.391-KTK Marco:P0385 Marco:P0386 Marco:P0387 Marco:P1998	2,50	Fijo Simple	Agujas	Zamak ZL5 Pintado Negro	90	180
c/ Suplemento 8,0 mm + 2 Suplementos Lat. 4,5 mm									

Cajetin 15,5 x 53,5 mm.

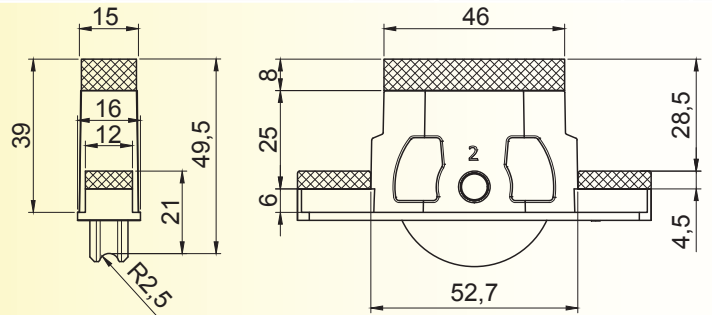

TP-2003-S08-A	Igual a la P-2003F-S08-A			2,50	Tándem Fijo Basculante	Agujas	Zamak ZL5 Pintado Negro Tirantes INOX	90	360
c/ 2 Suplementos 8,0 mm + 2 Suplementos Lat. 4,5 mm									

Cajetin 15,5 x 115 mm.

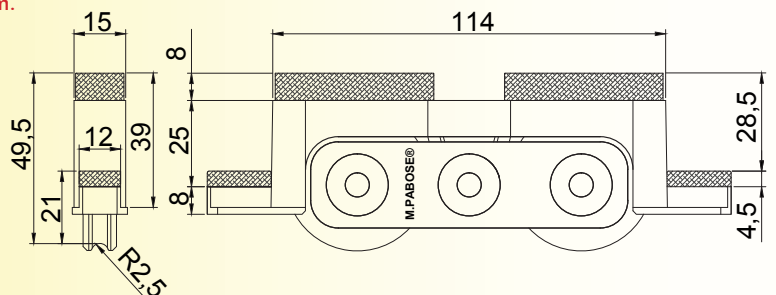

"Los suplementos de poliamida se suministran en bolsa aparte"

M. Pabose® como fabricante del producto se reserva el derecho de efectuar sin previo aviso, las modificaciones que considere oportunas para mejorar las prestaciones de sus productos.

Referencia	Extrusor/Cliente	Serie	Perfil	Rueda radio/ang.	Tipo de Conjunto	Rodamiento	Soporte	Carga (Kg)	
								Rueda	Hoja
P-2003F-S09-A	Veka	Ekosol H-89	Hoja: 105.241 Marco: 105.245 Marco: 105.720	2,25	Fijo Simple	Agujas	Zamak ZL5 Pintado Negro	80	160

c/ Suplemento 5 mm+ 2 Suplementos Lat. 3,5 mm.

Cajetin 15,5 x 53,5 mm.

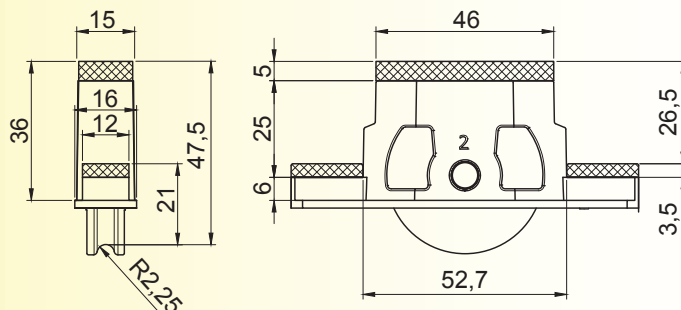
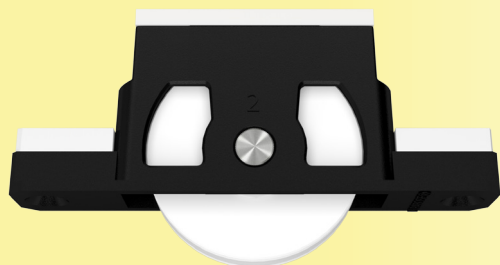

TP-2003-S09-A	Igual a la P-2003F-S09-A			2,25	Tándem Fijo Basculante	Agujas	Zamak ZL5 Pintado Negro Tirantes INOX	80	320
----------------------	--------------------------	--	--	------	---------------------------	--------	---	----	-----

c/ 2 Suplementos 5 mm+ 2 Suplementos Lat. 3,5 mm.

Cajetin 15,5 x 115 mm.

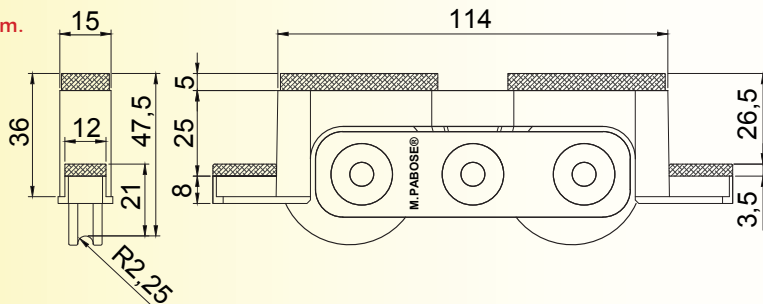

P-2003F-S10-A	Finstral	System 900		2,50	Fijo Simple	Agujas	Zamak ZL5 Pintado Negro	90	180
----------------------	----------	------------	--	------	-------------	--------	----------------------------	----	-----

c/ 2 Suplementos Lat. 3,5 mm

Cajetin 15,5 x 53,5 mm.

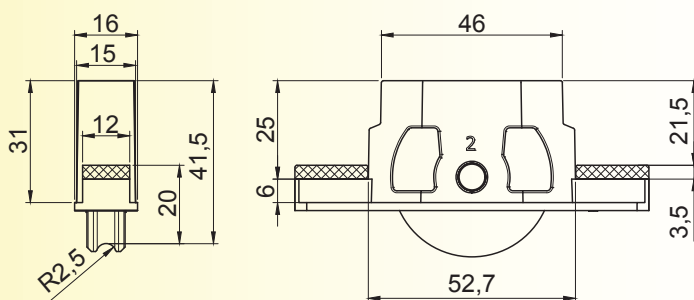
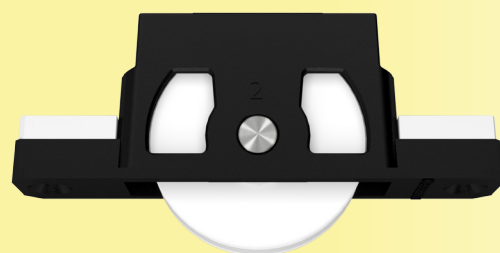

TP-2003-S10-A	Finstral	System 900		2,50	Tándem Fijo Basculante	Agujas	Zamak ZL5 Pintado Negro Tirantes INOX	90	360
----------------------	----------	------------	--	------	---------------------------	--------	---	----	-----

c/ 2 Suplementos Lat. 3,5 mm

Cajetin 15,5 x 115 mm.

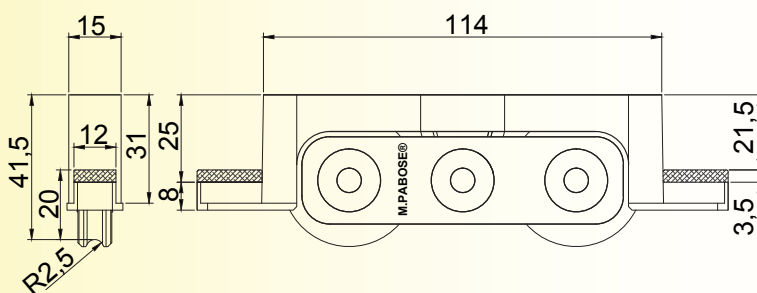

"Los suplementos de poliamida se suministran en bolsa aparte"

M. Pabose® como fabricante del producto se reserva el derecho de efectuar sin previo aviso, las modificaciones que considere oportunas para mejorar las prestaciones de sus productos.

Referencia	Extrusor/Cliente	Serie	Perfil	Rueda	Tipo de	Soporte	Carga (Kg)		
				radio/ang.			Conjunto	Rodamiento	Rueda
P-2003F-S11-A	A.G.B	Ekosol-90	Hoja: 105.312 Marco: 105.310	2,50	Fijo Simple	Agujas	Zamak ZL5 Pintado Negro	90	180
	PVTEC	Optima Perfil 93	Hoja: S-545.13 Marco: S-545.14						
	Veka	Ekosol-70	Hoja: 105.312 Marco: 105.310						
		Nova Ekosol CR-70	Hoja: 105.321 Marco: 105.351						
		Euroslide-70	Hoja: 105.321						
c/ Suplemento 7 + 2 Suplementos Lat. 3,5 mm									

Cajetin 15,5 x 53,5 mm.

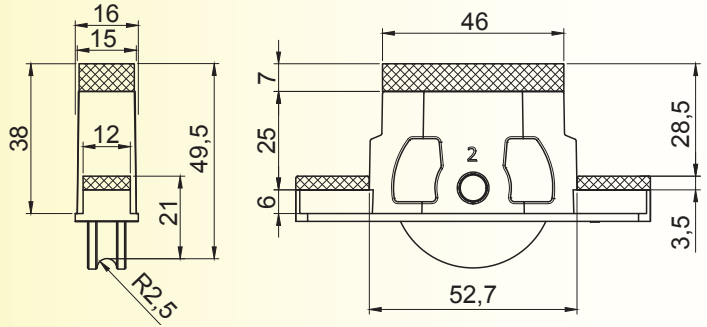

TP-2003-S11-A	Igual a la P-2003F-S11-A			2,50	Tándem Fijo Basculante	Agujas	Zamak ZL5 Pintado Negro Tirantes INOX	90	360
c/ 2 Suplementos 7 + 2 Suplementos Lat. 3,5 mm									

Cajetin 15,5 x 115 mm.

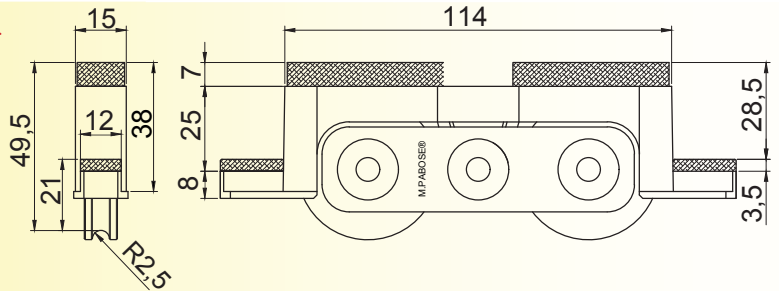

P-2003F-S12-A	Veka	Soffline CR-73	Hoja: 105.715 Marco: 105.701	2,50	Fijo Simple	Agujas	Zamak ZL5 Pintado Negro	90	180
c/ Suplemento 2,5 + 2 Suplementos Lat. 5,5 mm									

Cajetin 15,5 x 53,5 mm.

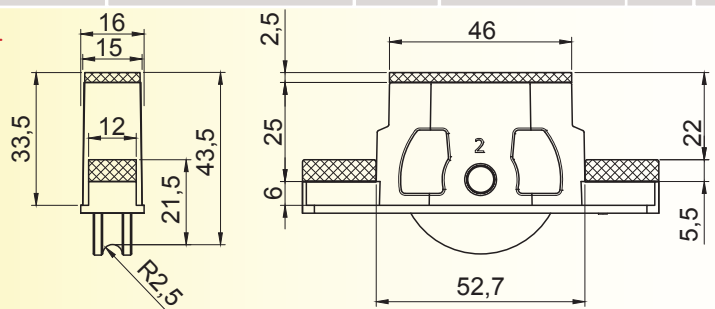

TP-2003-S12-A	Veka	Soffline CR-73	Hoja: 105.715 Marco: 105.701	2,50	Tándem Fijo Basculante	Agujas	Zamak ZL5 Pintado Negro Tirantes INOX	90	360
c/ 2 Suplementos 2,5 + 2 Suplementos Lat. 5,5 mm									

Cajetin 15,5 x 115 mm.

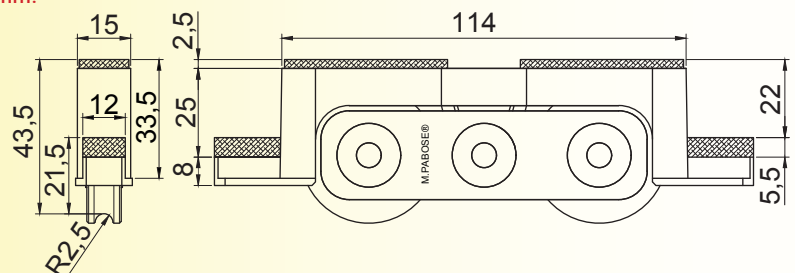

"Los suplementos de poliamida se suministran en bolsa aparte"

M. Pabose® como fabricante del producto se reserva el derecho de efectuar sin previo aviso, las modificaciones que considere oportunas para mejorar las prestaciones de sus productos.

Referencia	Extrusor/Cliente	Serie	Perfil	Rueda radio/ang.	Tipo de Conjunto	Tipo de Rodamiento	Soporte	Carga (Kg)	
								Rueda	Hoja
P-2003F-S13-A	Rehau	Serie 920	Hoja:500.043 Marco:500.013	2,50	Fijo Simple	Agujas	Zamak ZL5 Pintado Negro	90	180
	Salamander	SF76	Hoja:601.138 Marco:600.128						
c/ Suplemento 4 mm c/ Chaflan Lat. superior									

Cajetin 15,5 x 53,5 mm.

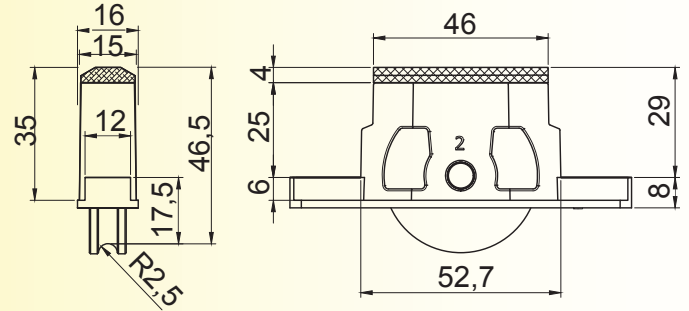

TP-2003-S13-A	Igual a la P-2003F-S13-A			2,50	Tándem Fijo Basculante	Agujas	Zamak ZL5 Pintado Negro Tirantes INOX	90	360
c/ 2 Suplementos 4 mm c/ Chaflan Lat. superior									

Cajetin 15,5 x 115 mm.

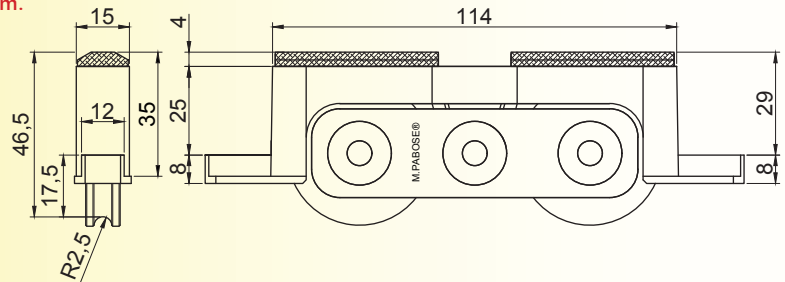

P-2003F-S14-A	Herrajes Norm Metal		Hoja:997.406 Marco:997.402	3,30	Fijo Simple	Agujas	Zamak ZL5 Pintado Negro	100	200
c/ Suplemento 2,5 mm									

Cajetin 15,5 x 53,5 mm.

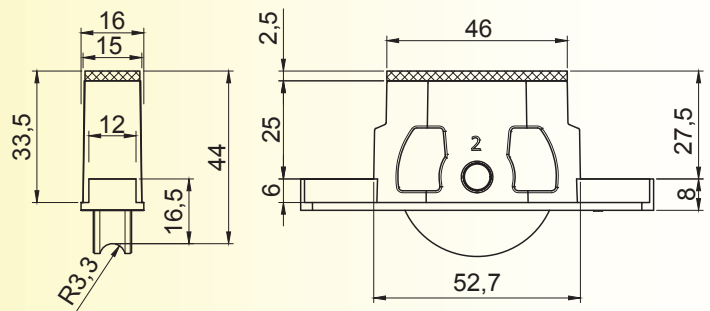
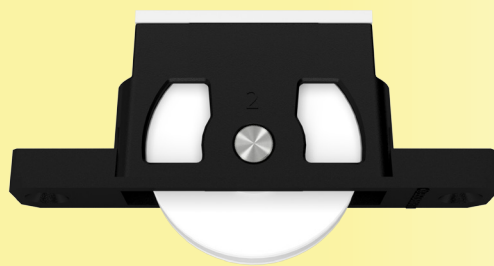

TP-2003-S14-A	Herrajes Norm Metal		Hoja:997.406 Marco:997.402	3,30	Tándem Fijo Basculante	Agujas	Zamak ZL5 Pintado Negro Tirantes INOX	100	400
c/ 2 Suplementos 2,5 mm									

Cajetin 15,5 x 115 mm.

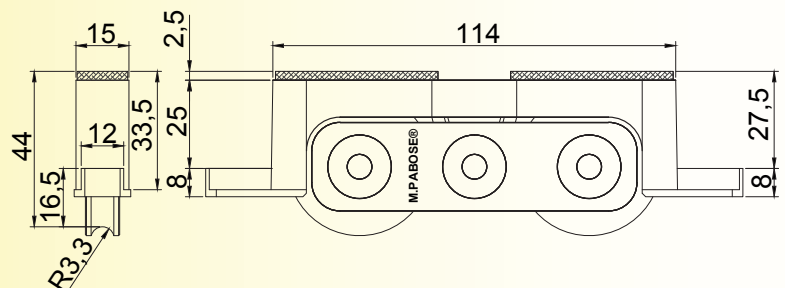

"Los suplementos de poliamida se suministran en bolsa aparte"

M. Pabose® como fabricante del producto se reserva el derecho de efectuar sin previo aviso, las modificaciones que considere oportunas para mejorar las prestaciones de sus productos.

Referencia	Extrusor/Cliente	Serie	Perfil	Rueda	Tipo de	Soporte	Carga (Kg)		
				radio/ang.			Conjunto	Rodamiento	Rueda
P-2003F-S15-A	Tecnocom Linea Newen	DZ 89-46 Refuerzo 2009/1	Hoja:PH1010 Marco:PM1250 Marco:PM1260 Marco:AU4032	2,50	Fijo Simple	Agujas	Zamak ZL5 Pintado Negro	90	180

Cajetin 15,5 x 53,5 mm.

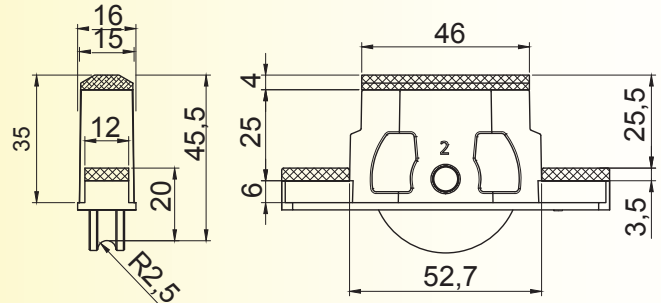

TP-2003-S15-A	Igual a la P-2003F-S15-A			2,50	Tándem Fijo Basculante	Agujas	Zamak ZL5 Pintado Negro Tirantes INOX	90	360

Cajetin 15,5 x 115 mm.

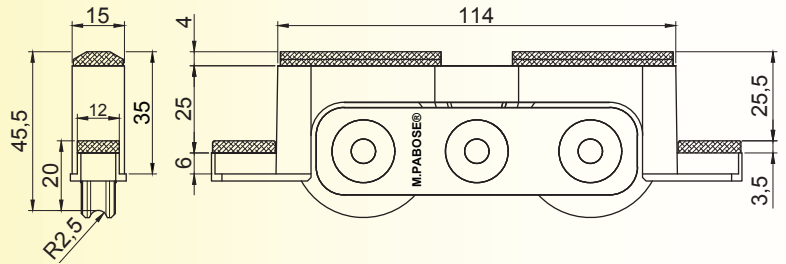

P-2003F-S16-A	Archicentro	Hoja:111		2,50	Fijo Simple	Agujas	Zamak ZL5 Pintado Negro	90	180

Cajetin 15,5 x 53,5 mm.

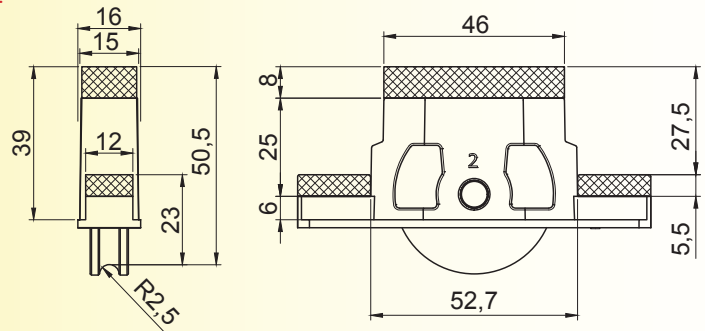

TP-2003-S16-A	Archicentro	Hoja:111		2,50	Tándem Fijo Basculante	Agujas	Zamak ZL5 Pintado Negro Tirantes INOX	90	360

Cajetin 15,5 x 115 mm.

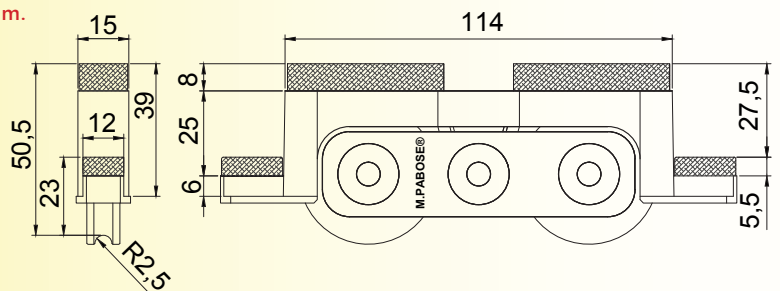

"Los suplementos de poliamida se suministran en bolsa aparte"

M. Pabose® como fabricante del producto se reserva el derecho de efectuar sin previo aviso, las modificaciones que considere oportunas para mejorar las prestaciones de sus productos.

Referencia	Extrusor/Cliente	Serie	Perfil	Rueda radio/ang.	Tipo de Conjunto	Tipo de Rodamiento	Soporte	Carga (Kg)	
								Rueda	Hoja
P-2003F-S17-A	Deceunink		Hoja:12.671	2,50	Fijo Simple	Agujas	Zamak ZL5 Pintado Negro	90	180

Cajetin 15,5 x 53,5 mm.

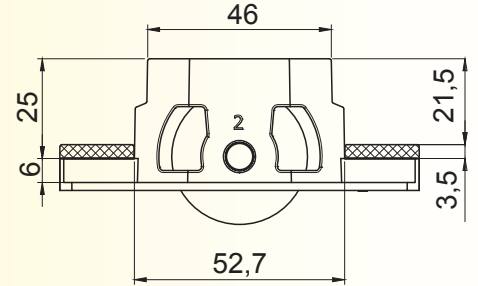
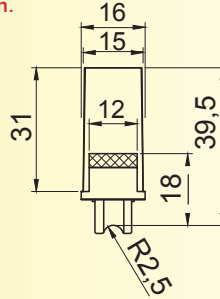

TP-2003-S17-A	Deceunink		Hoja:12.671	2,50	Tándem Fijo Basculante	Agujas	Zamak ZL5 Pintado Negro Tirantes INOX	90	360

Cajetin 15,5 x 115 mm.

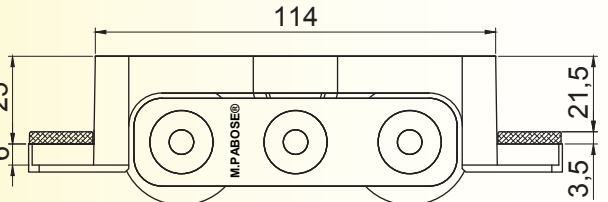
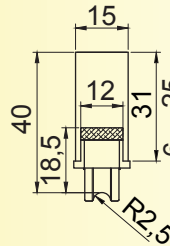

P-2003F-S18-A	Glasstech		Hoja: SF-92 Marco: SF-62	2,25	Fijo Simple	Agujas	Zamak ZL5 Pintado Negro	80	160

Cajetin 15,5 x 53,5 mm.

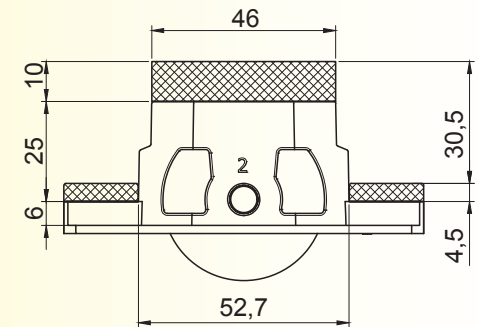
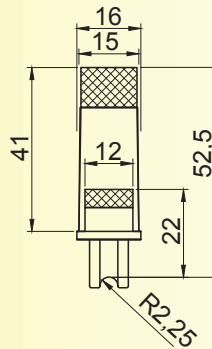

TP-2003-S18-A	Glasstech		Hoja: SF-92 Marco: SF-62	2,25	Tándem Fijo Basculante	Agujas	Zamak ZL5 Pintado Negro Tirantes INOX	80	320

Cajetin 15,5 x 115 mm.

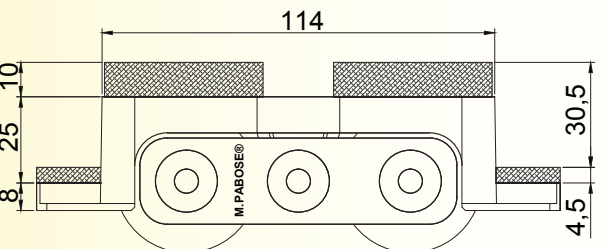
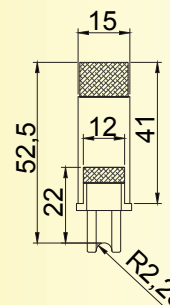

"Los suplementos de poliamida se suministran en bolsa aparte"

M. Pabose® como fabricante del producto se reserva el derecho de efectuar sin previo aviso, las modificaciones que considere oportunas para mejorar las prestaciones de sus productos.

Referencia	Extrusor/Cliente	Serie	Perfil	Rueda radio/ang.	Tipo de Conjunto	Tipo de Rodamiento	Soporte	Carga (Kg)	
								Rueda	Hoja

P-2003F-S19-A	Rehau	920	Hoja:500.403 Marco:500.003	2,50	Fijo Simple	Agujas	Zamak ZL5 Pintado Negro	90	180
	c/ Suplemento 4 mm c/ Chaflan Lat. Superior +2 Suplementos Lat. 4,5 mm								

Cajetin 15,5 x 53,5 mm.

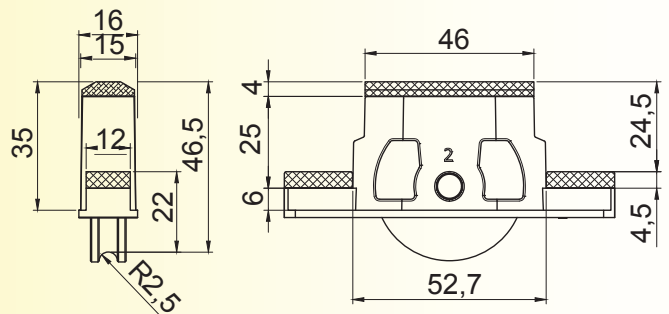

TP-2003-S19-A	Rehau	920	Hoja:500.403 Marco:500.003	2,50	Tándem Fijo Basculante	Agujas	Zamak ZL5 Pintado Negro Tirantes INOX	90	360
	c/ 2 Suplementos 4 mm c/ Chaflan Lat. Superior +2 Suplementos Lat. 4,5 mm								

Cajetin 15,5 x 115 mm.

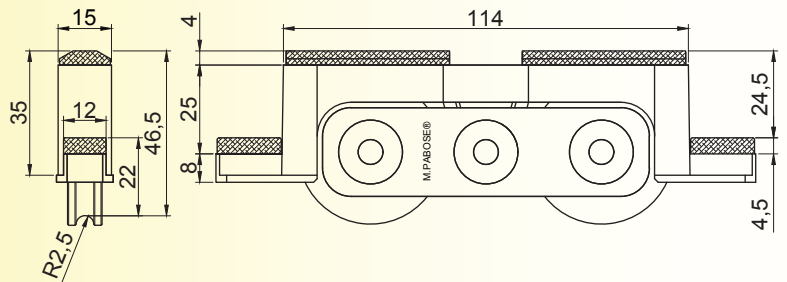

P-2003F-S20-A	Gealan	SF-74	Hoja:5805 Marco:5802	2,50	Fijo Simple	Agujas	Zamak ZL5 Pintado Negro	90	180
	c/ Suplemento 2,5 mm+2 Suplementos Lat. 3,5 mm								

Cajetin 15,5 x 53,5 mm.

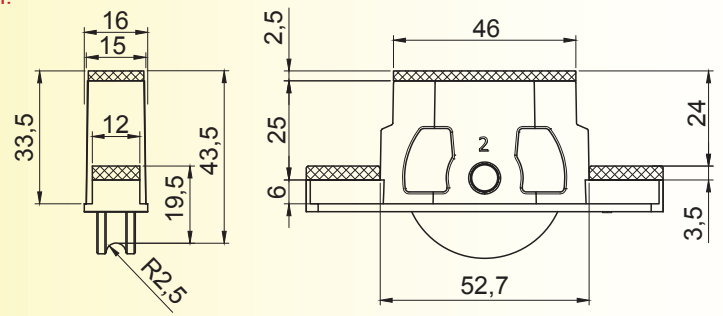

TP-2003-S20-A	Gealan	SF-74	Hoja:5805 Marco:5802	2,50	Tándem Fijo Basculante	Agujas	Zamak ZL5 Pintado Negro Tirantes INOX	90	360
	c/ 2 Suplementos 2,5 mm+2 Suplementos Lat. 3,5 mm								

Cajetin 15,5 x 115 mm.

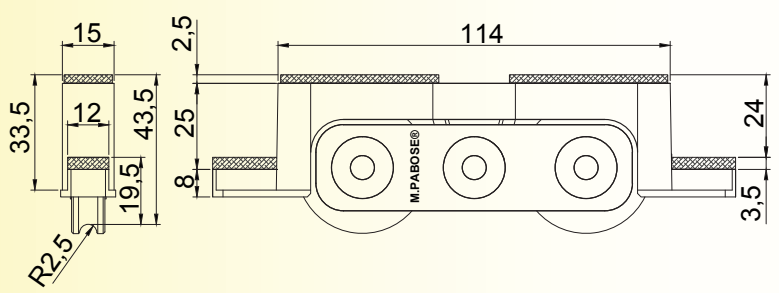

"Los suplementos de poliamida se suministran en bolsa aparte"

M. Pabose® como fabricante del producto se reserva el derecho de efectuar sin previo aviso, las modificaciones que considere oportunas para mejorar las prestaciones de sus productos.

Referencia	Extrusor/Cliente	Serie	Perfil	Rueda radio/ang.	Tipo de		Soporte	Carga (Kg)	
					Conjunto	Rodamiento		Rueda	Hoja
P-2003F-S21-A	Ferbrás		Hoja:7402 Marco:7401	3,30	Fijo Simple	Agujas	Zamak ZL5 Pintado Negro	100	200

Cajetin 15,5 x 53,5 mm.

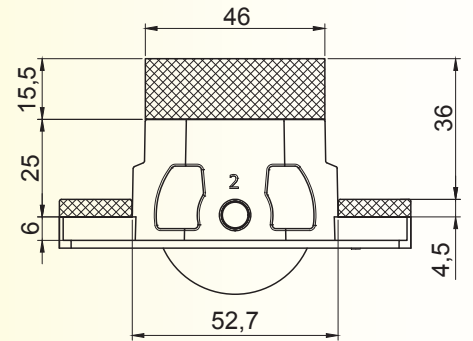
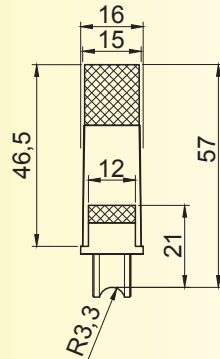

TP-2003-S21-A	Ferbrás		Hoja:7402 Marco:7401	3,30	Tándem Fijo Basculante	Agujas	Zamak ZL5 Pintado Negro Tirantes INOX	100	400

Cajetin 15,5 x 115 mm.

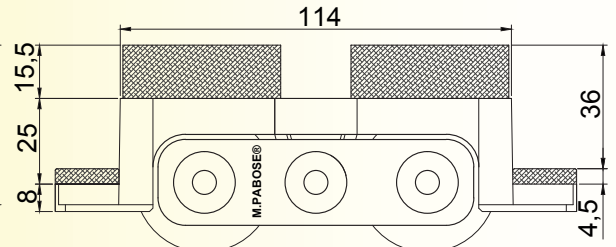
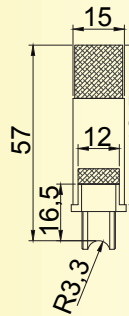

P-2003F-S22-A	Rehau	920-SA 920-SD		2,25	Fijo Simple	Agujas	Zamak ZL5 Pintado Negro	80	160

Cajetin 15,5 x 53,5 mm.

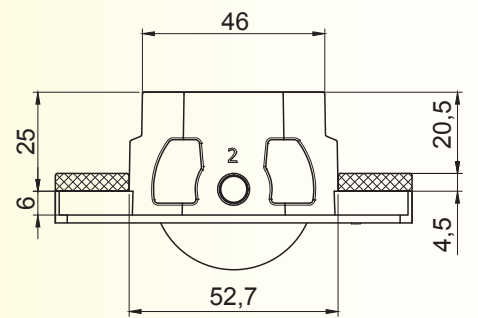
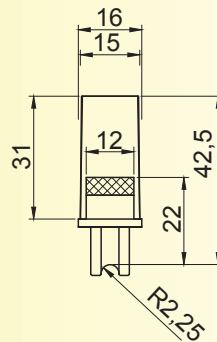

TP-2003-S22-A	Rehau	920-SA 920-SD		2,25	Tándem Fijo Basculante	Agujas	Zamak ZL5 Pintado Negro Tirantes INOX	80	320

Cajetin 15,5 x 115 mm.

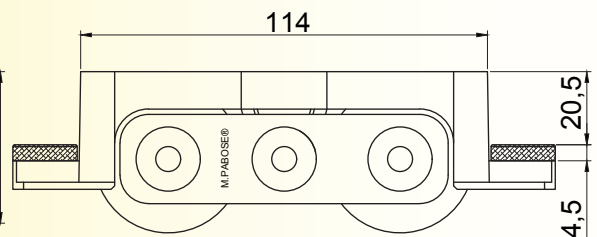
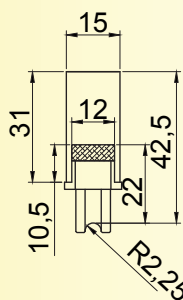

"Los suplementos de poliamida se suministran en bolsa aparte"

M. Pabose® como fabricante del producto se reserva el derecho de efectuar sin previo aviso, las modificaciones que considere oportunas para mejorar las prestaciones de sus productos.

Referencia	Extrusor/Cliente	Serie	Perfil	Rueda radio/ang.	Tipo de		Soporte	Carga (Kg)	
					Conjunto	Rodamiento		Rueda	Hoja
P-2003F-S23-A	Deceuninck	920-HD	Hoja: 12671 c/ Rfzo. 1,4 mm	2,50	Fijo Simple	Agujas	Zamak ZL5 Pintado Negro	90	180
		920-SA	Marco: 12661						
c/ 2 Suplementos Lat. 2,5 mm									

Cajetin 15,5 x 53,5 mm.

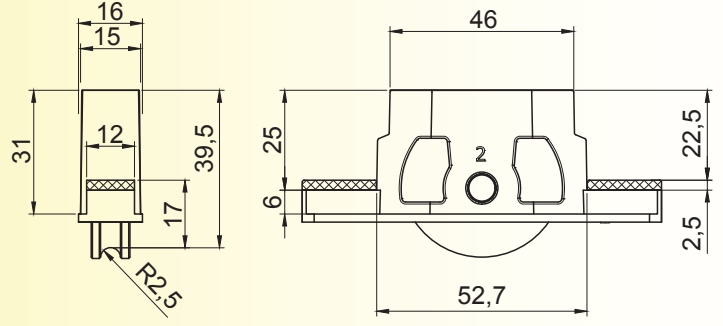

TP-2003-S23-A	Igual a la P-2003F-S23-A			2,50	Tándem Fijo Basculante	Agujas	Zamak ZL5 Pintado Negro Tirantes INOX	90	360
	c/ 2 Suplementos Lat. 2,5 mm								

Cajetin 15,5 x 115 mm.

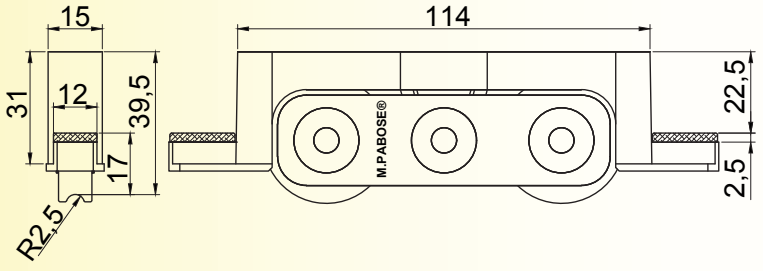

P-2003F-S24-A	Varias			2,50	Fijo Simple	Agujas	Zamak ZL5 Pintado Negro	90	180
	c/ Suplemento 18,6 mm + 2 Suplementos Lat.4,5 mm								

Cajetin 15,5 x 53,5 mm.

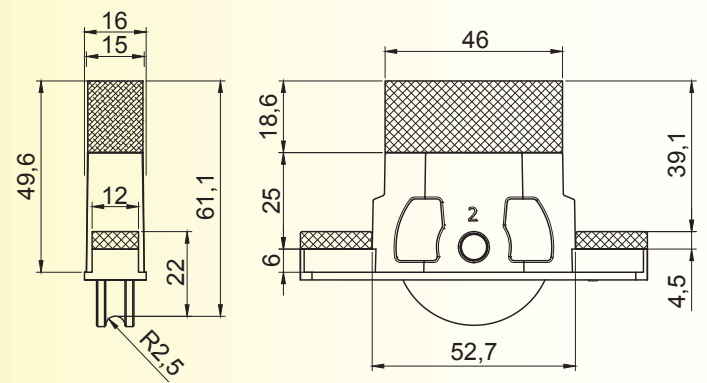

TP-2003-S24-A	Varias			2,50	Tándem Fijo Basculante	Agujas	Zamak ZL5 Pintado Negro Tirantes INOX	90	360
	c/ 2 Suplementos 18,6 mm + 2 Suplementos Lat.4,5 mm								

Cajetin 15,5 x 115 mm.

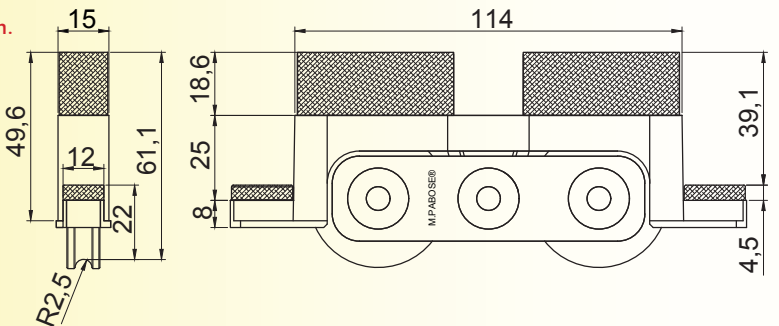
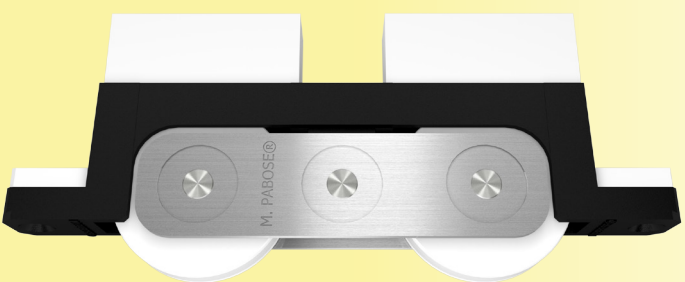

"Los suplementos de poliamida se suministran en bolsa aparte"

M. Pabose® como fabricante del producto se reserva el derecho de efectuar sin previo aviso, las modificaciones que considere oportunas para mejorar las prestaciones de sus productos.

Referencia	Extrusor/Cliente	Serie	Perfil	Rueda radio/ang.	Tipo de		Soporte	Carga (Kg)	
					Conjunto	Rodamiento		Rueda	Hoja
P-2003F-S25-A	Aluplast		Hoja: 100x74	2,50	Fijo Simple	Agujas	Zamak ZL5 Pintado Negro	90	180
			Marco: 100071						
			c/ Suplemento 3,5 mm+ 2 Suplementos Lat.4,5 mm						

Cajetin 15,5 x 53,5 mm.

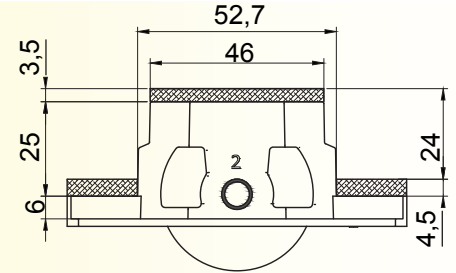
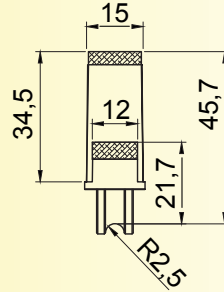

TP-2003-S25-A	Aluplast		Hoja: 100x74	2,50	Tándem Fijo Basculante	Agujas	Zamak ZL5 Pintado Negro Tirantes INOX	90	360
			Marco: 100071						
			c/ 2 Suplementos 3,5 mm+ 2 Suplementos Lat.4,5 mm						

Cajetin 15,5 x 115 mm.

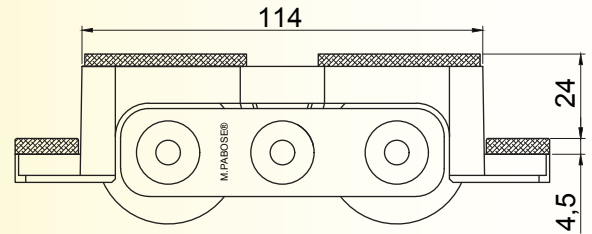
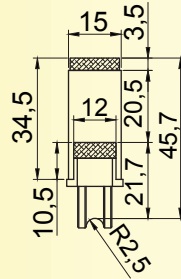

P-2003F-S26-A	Uniplast		Hoja: USS103	2,50	Fijo Simple	Agujas	Zamak ZL5 Pintado Negro	90	180
			Marco: USS101						
			Marco: USS102						
			c/ 2 Suplementos Lat.4,5 mm						

Cajetin 15,5 x 53,5 mm.

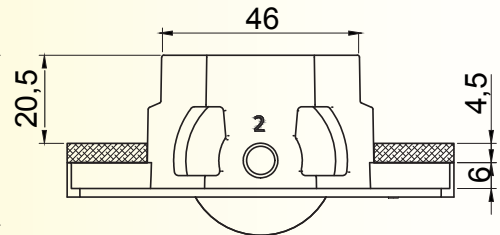
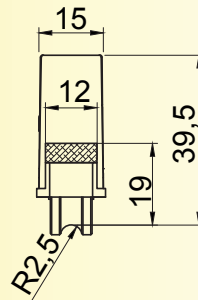

TP-2003-S26-A	Uniplast		Hoja: USS103	2,50	Tándem Fijo Basculante	Agujas	Zamak ZL5 Pintado Negro Tirantes INOX	90	360
			Marco: USS101						
			Marco: USS102						
			c/ 2 Suplementos Lat.4,5 mm						

Cajetin 15,5 x 115 mm.

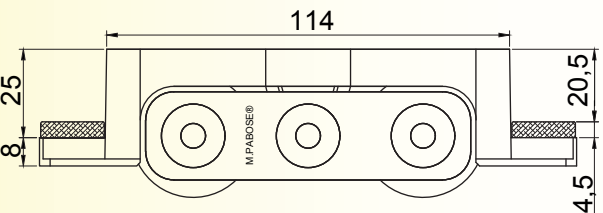
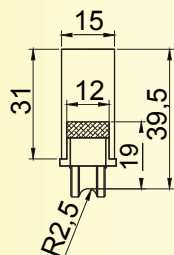

"Los suplementos de poliamida se suministran en bolsa aparte"

M. Pabose® como fabricante del producto se reserva el derecho de efectuar sin previo aviso, las modificaciones que considere oportunas para mejorar las prestaciones de sus productos.

Referencia	Extrusor/Cliente	Serie	Perfil	Rueda radio/ang.	Tipo de Conjunto	Rodamiento	Soporte	Carga (Kg)	
								Rueda	Hoja

P-2003F-S27-A	Tecnocom	Línea Jumbo Corredera Pesada		3,30	Fijo Simple	Agujas	Zamak ZL5 Pintado Negro	100	200
	c/ Suplemento 18,6 mm+ 2 Suplementos Lat.4,5 mm								

Cajetin 15,5 x 53,5 mm.

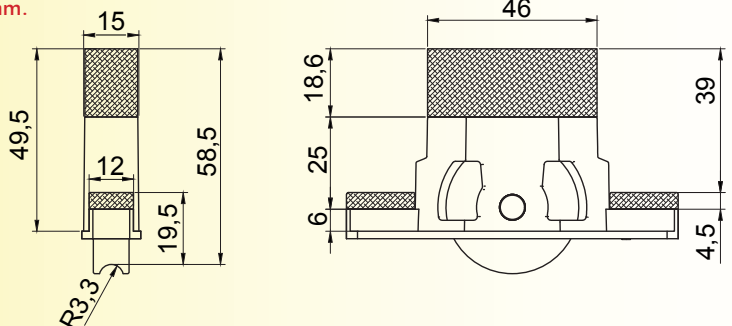
TP-2003-S27-A	Tecnocom	Línea Jumbo Corredera Pesada		3,30	Tándem Fijo Basculante	Agujas	Zamak ZL5 Pintado Negro Tirantes INOX	100	400
	c/ 2 Suplementos 18,6 mm+ 2 Suplementos Lat.4,5 mm								

Cajetin 15,5 x 115 mm.

P-2003F-S28-A	Tecnocom	Línea Prime		2,50	Fijo Simple	Agujas	Zamak ZL5 Pintado Negro	90	180
	c/ Suplemento 6 mm+ 2 Suplementos Lat.4,5 mm								

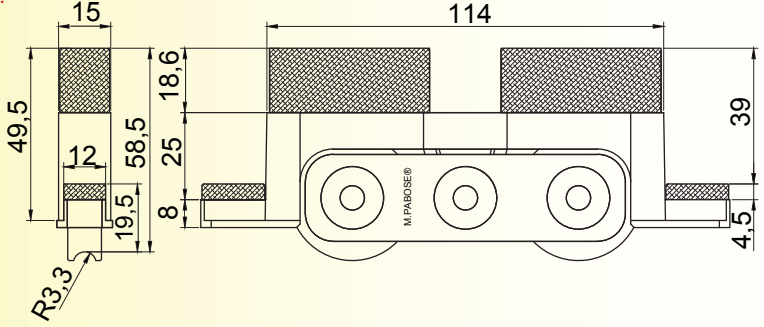
Cajetin 15,5 x 53,5 mm.

TP-2003-S28-A	Tecnocom	Línea Prime		2,50	Tándem Fijo Basculante	Agujas	Zamak ZL5 Pintado Negro Tirantes INOX	90	360
	c/ 2 Suplementos 6 mm+ 2 Suplementos Lat.4,5 mm								

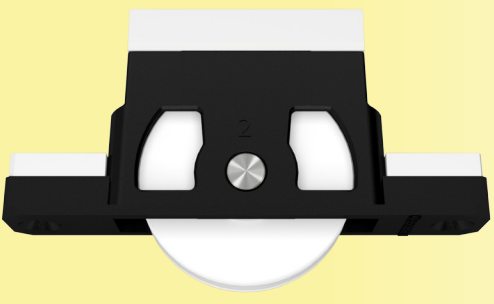
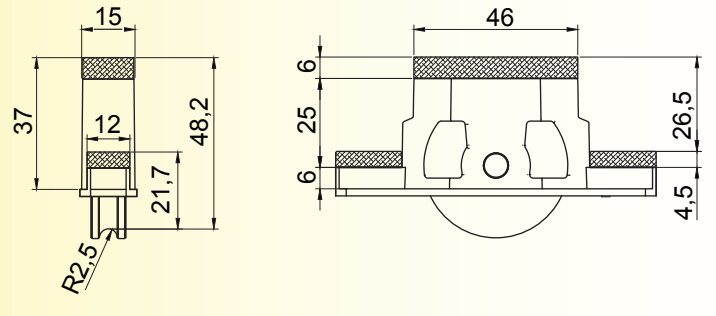
Cajetin 15,5 x 115 mm.



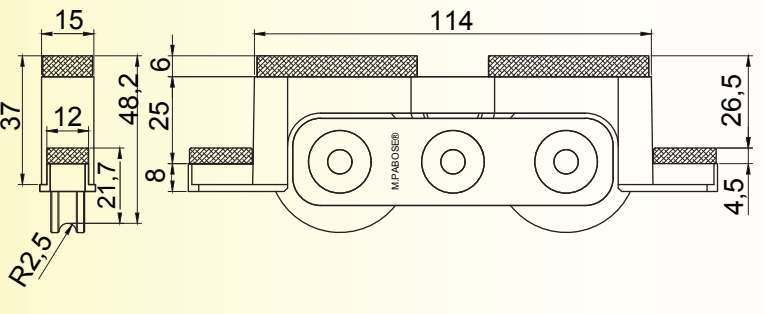

"Los suplementos de poliamida se suministran en bolsa aparte"

M. Pabose® como fabricante del producto se reserva el derecho de efectuar sin previo aviso, las modificaciones que considere oportunas para mejorar las prestaciones de sus productos.

Referencia	Extrusor/Cliente	Serie	Perfil	Rueda radio/ang.	Tipo de Conjunto	Tipo de Rodamiento	Soporte	Carga (Kg)	
								Rueda	Hoja
P-2003F-S29-A	Aluplast		Hoja: 100392	2,50	Fijo Simple	Agujas	Zamak ZL5 Pintado Negro	90	180

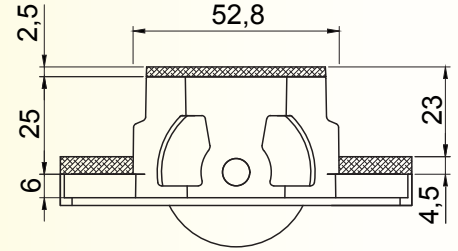
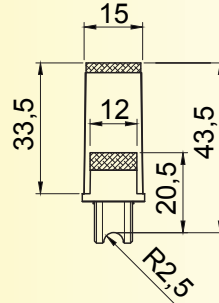
Cajetin 15,5 x 53,5 mm.



TP-2003-S29-A	Aluplast		Hoja: 100392	2,50	Tándem Fijo Basculante	Agujas	Zamak ZL5 Pintado Negro Tirantes INOX	90	360

Cajetin 15,5 x 115 mm.

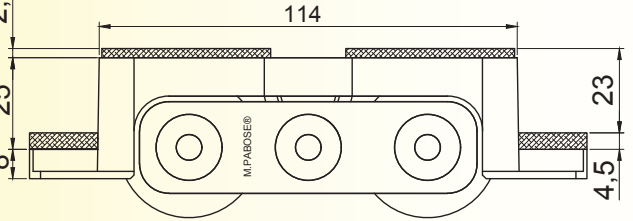
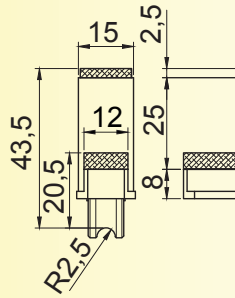

P-2003F-S30-A	Schüco		Hoja: 8820	2,50	Fijo Simple	Agujas	Zamak ZL5 Pintado Negro	90	180

Cajetin 15,5 x 53,5 mm.

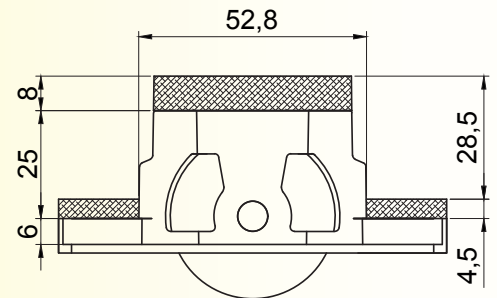
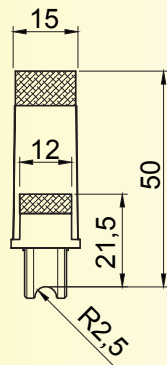
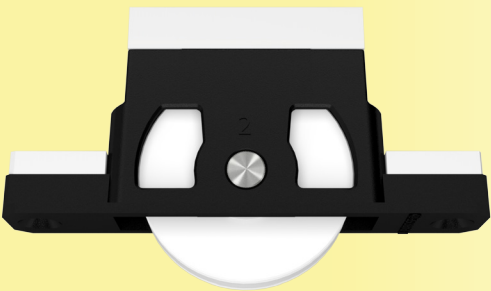

TP-2003-S30-A	Schüco		Hoja: 8820	2,50	Tándem Fijo Basculante	Agujas	Zamak ZL5 Pintado Negro Tirantes INOX	90	360

Cajetin 15,5 x 115 mm.

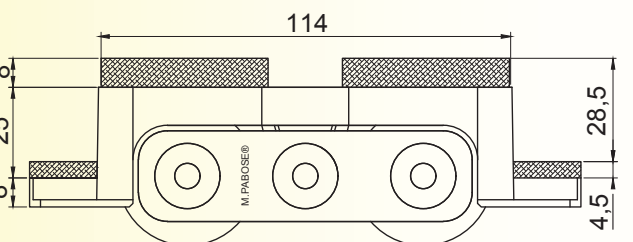
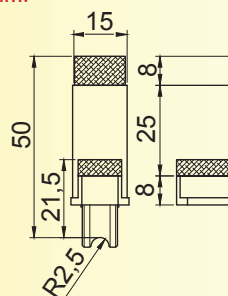

"Los suplementos de poliamida se suministran en bolsa aparte"

M. Pabose® como fabricante del producto se reserva el derecho de efectuar sin previo aviso, las modificaciones que considere oportunas para mejorar las prestaciones de sus productos.

Referencia	Extrusor/Cliente	Serie	Perfil	Rueda	Tipo de		Soporte		Carga (Kg)	
				radio/ang.	Conjunto	Rodamiento		Rueda	Hoja	

P-2003F-S31-A	Varias	2,25	Fijo Simple	Agujas	Zamak ZL5 Pintado Negro	80	160
	c/ Suplemento 5 mm						

Cajetin 15,5 x 53,5 mm.

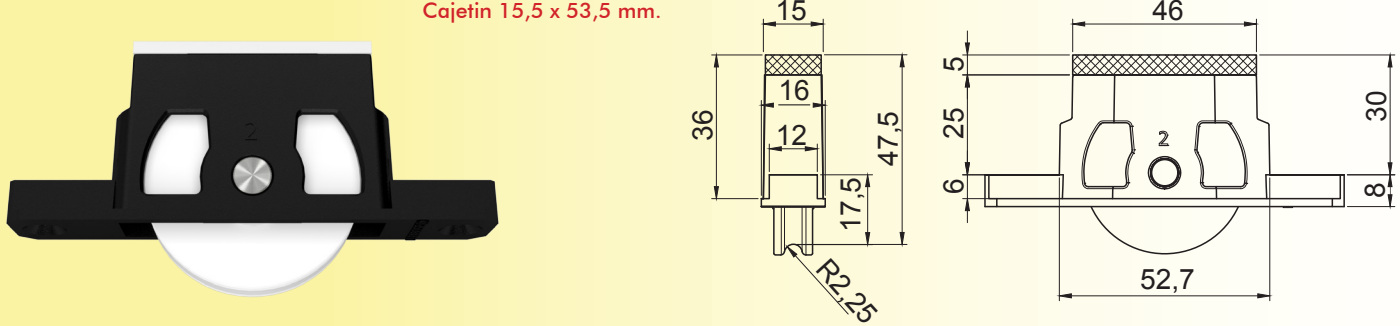

TP-2003-S31-A	Varias	2,25	Tándem Fijo Basculante	Agujas	Zamak ZL5 Pintado Negro Tirantes INOX	80	320
	c/ Suplemento 5 mm						

Cajetin 15,5 x 115 mm.

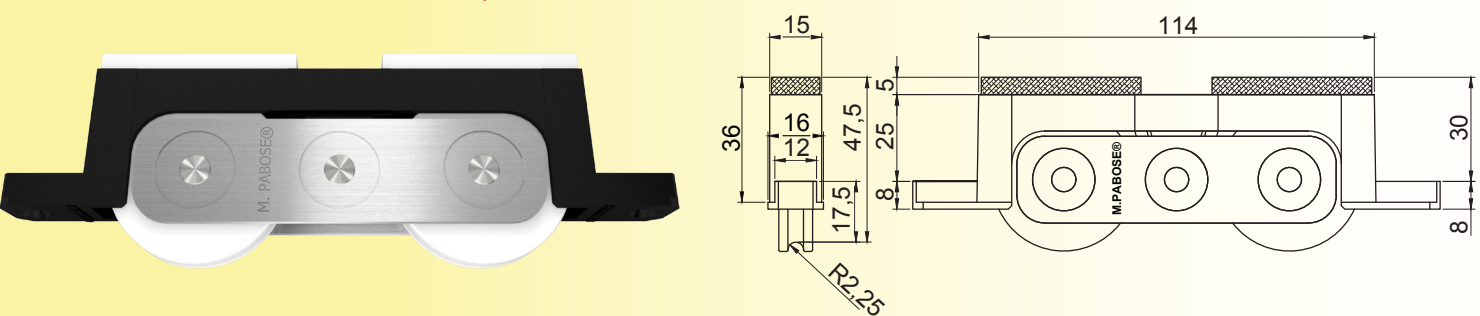

P-2003F-S32-A	Varias	2,50	Fijo Simple	Agujas	Zamak ZL5 Pintado Negro	90	180
	c/ Suplemento 5 mm+ 2 Suplementos Lat.3,5 mm						

Cajetin 15,5 x 53,5 mm.

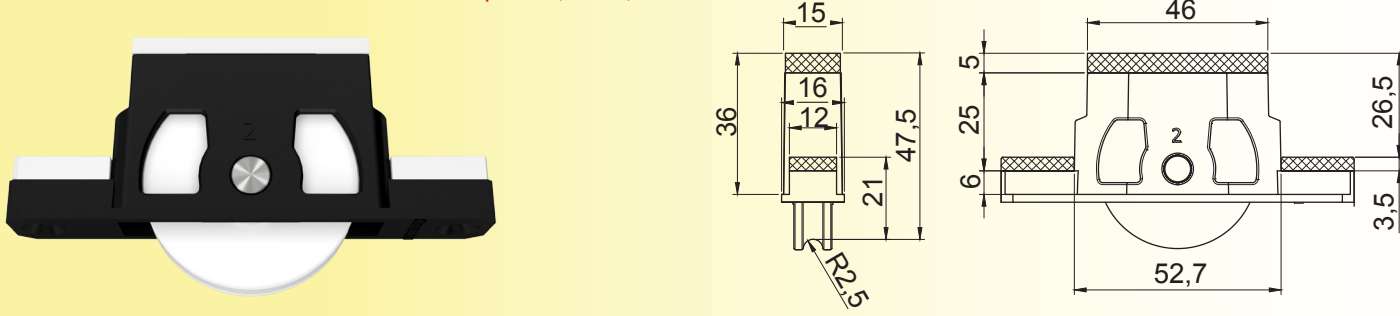

TP-2003-S32-A	Varias	2,50	Tándem Fijo Basculante	Agujas	Zamak ZL5 Pintado Negro Tirantes INOX	90	360
	c/ 2 Suplementos 5mm+ 2 Suplementos Lat.3,5 mm						

Cajetin 15,5 x 115 mm.

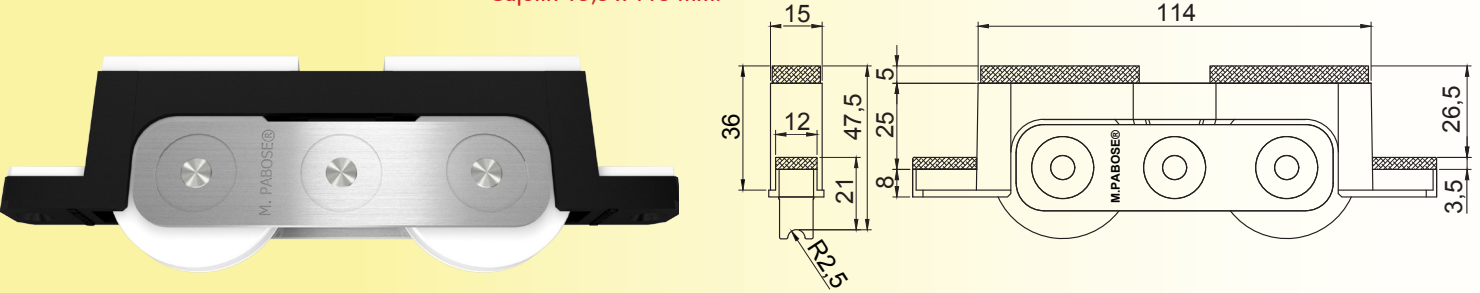

“Los suplementos de poliamida se suministran en bolsa aparte”

M. Pabose® como fabricante del producto se reserva el derecho de efectuar sin previo aviso, las modificaciones que considere oportunas para mejorar las prestaciones de sus productos.

Referencia	Conjunto	Soporte	Rodamiento
Serie TP4-2018	Doble Tándem 4 ruedas Basculación Independiente	Zamak ZL5 Pintado Negro Tirantes INOX	Agujas Rodadura acetal

Sistemas no elevables con canal de 22 mm

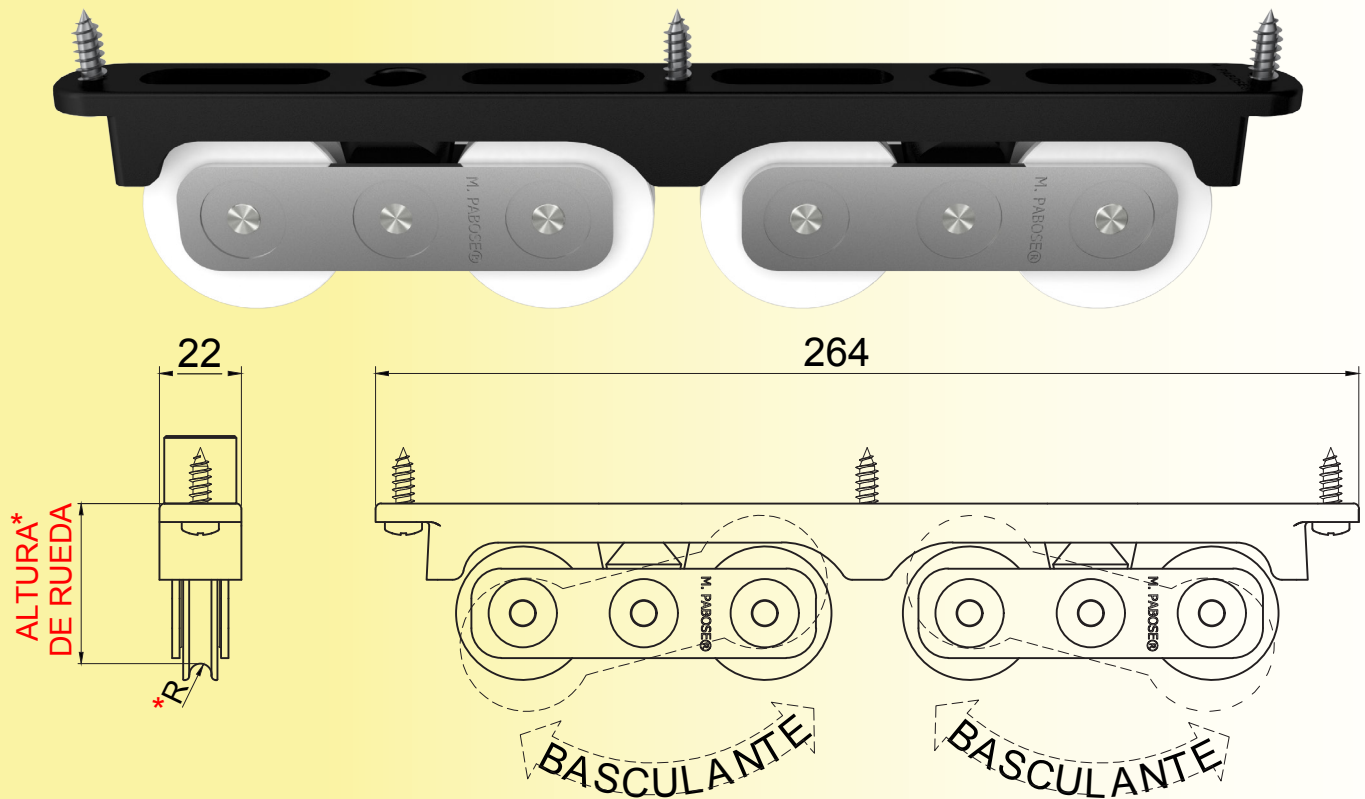

BASCULACIÓN DOBLE INDEPENDIENTE

* LAS MEDIDAS DE ALTURA DE RUEDA Y EL RADIO DE LAS RUEDAS VARIAN SEGÚN LAS NECESIDADES DE CADA CLIENTE.

CAPACIDAD MÁXIMA DE CARGA RECOMENDADA:

De 400 Kg a 800 Kg por hoja según las características y dimensiones de las ruedas

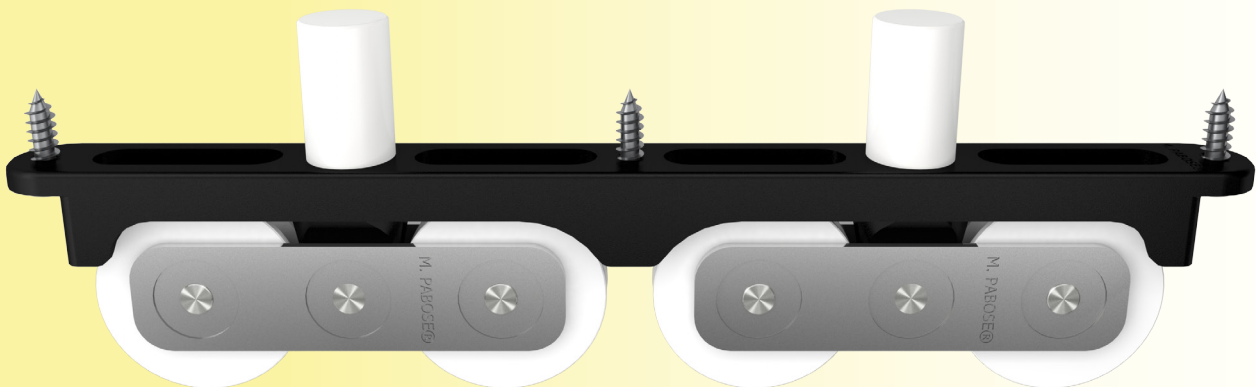

TOPES OPCIONALES: Se le puede añadir dos topes fijados en la parte superior del soporte según la necesidad de cada cliente.

Referencia	Conjunto	Soporte	Rodamiento
Serie TP4-2018	Doble Tándem 4 ruedas Basculación Independiente	Zamak ZL5 Pintado Negro Tirantes INOX	Agujas Rodadura Inox.

Sistemas no elevables con canal de 22 mm

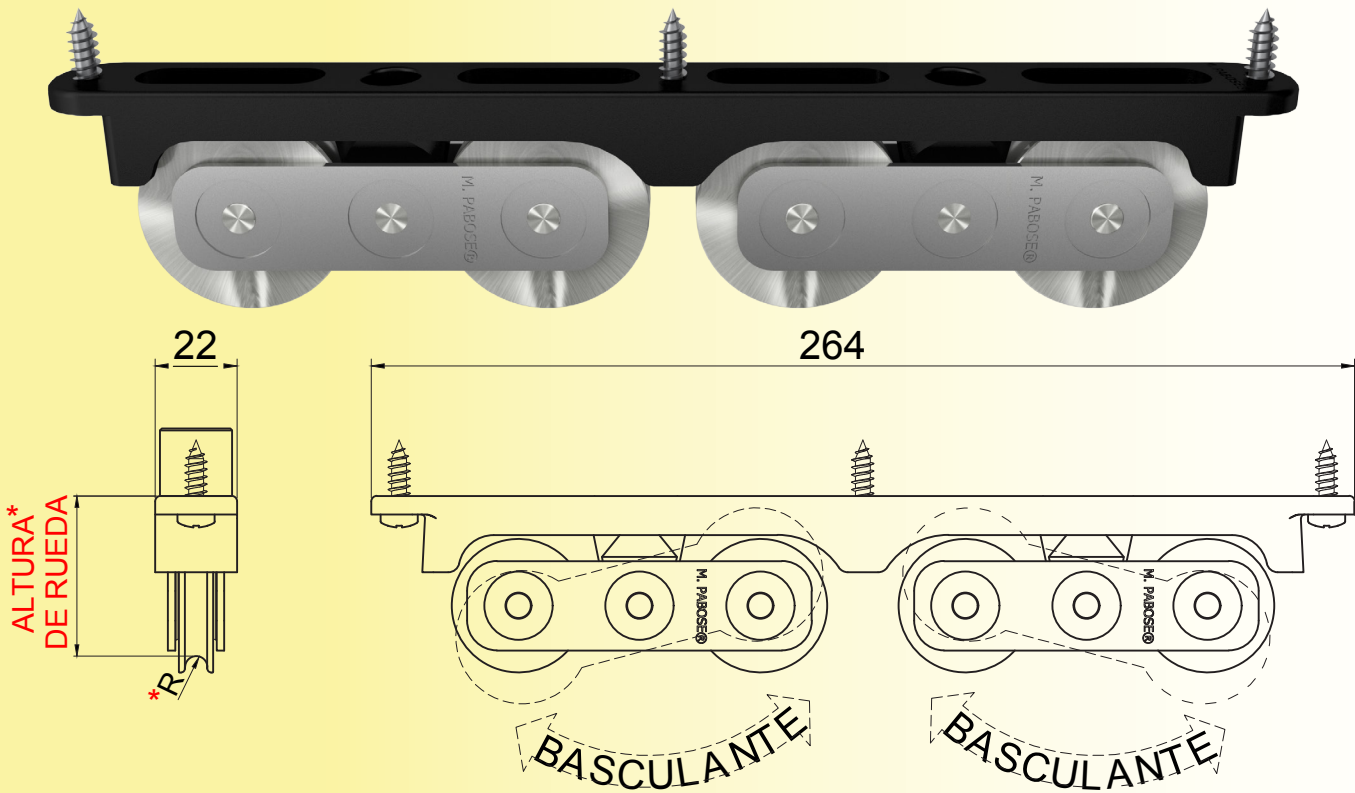

BASCULACIÓN DOBLE INDEPENDIENTE

* LAS MEDIDAS DE ALTURA DE RUEDA Y EL RADIO DE LAS RUEDAS VARIAN SEGÚN LAS NECESIDADES DE CADA CLIENTE.

CAPACIDAD MÁXIMA DE CARGA RECOMENDADA:

Hasta 1000 Kg por hoja según las características y dimensiones de las ruedas

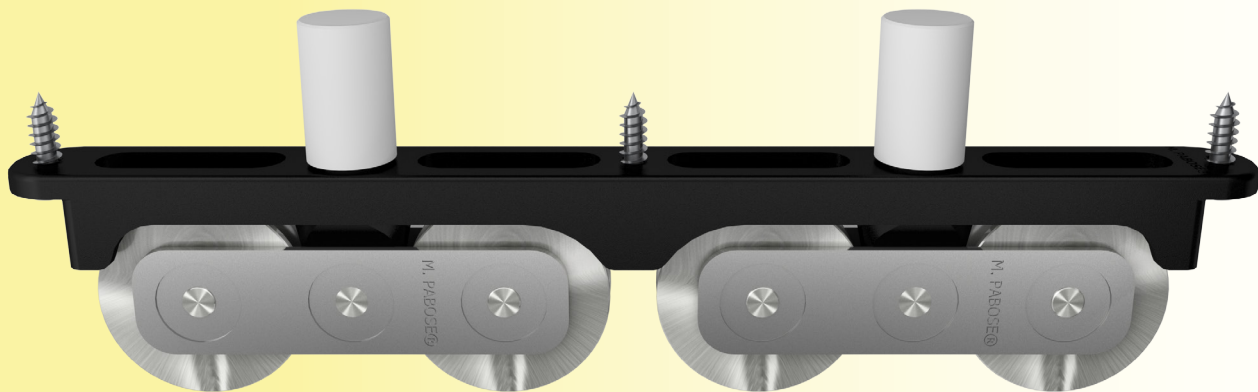

TOPES OPCIONALES: Se le puede añadir dos topes fijados en la parte superior del soporte para aumentar la altura según la necesidad de cada cliente.

Referencia	Extrusor/Cliente	Serie	Perfil	Rueda radio/ang.	Tipo de Conjunto	Rodamiento	Soporte	Carga (Kg)	
								Rueda	Hoja
P-20/22-01-A		Varias		2,50	Fijo Simple	Agujas	Zamak ZL5 Pintado Negro	40	80

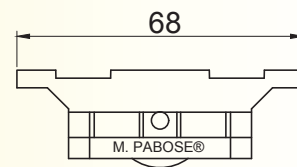
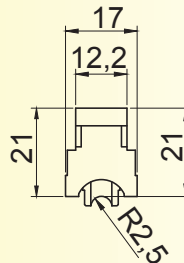
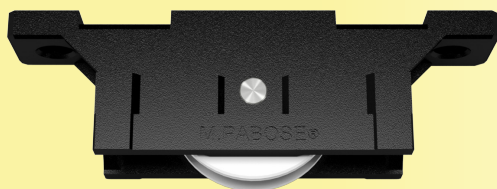

P-20/22-S02-A		Varias		2,50	Fijo Simple	Agujas	Zamak ZL5 Pintado Negro	40	80
----------------------	--	--------	--	------	-------------	--------	----------------------------	----	----

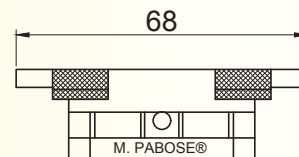
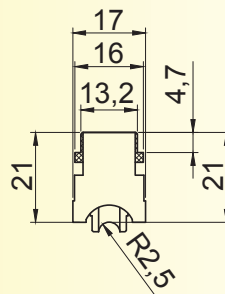

P-2002	Aluplast	SF-73	Hoja: 100x82 Marco: 100.080	2,50	Fijo Simple	Bolas	Zamak ZL5 Pintado Negro	15	30
	Gealan		Hoja: 3083-62 Hoja: 3083-63 Marco: 3029-24						
	Kömmerling	Premiline	Hoja: 6.041 Marco: 6.050 Marco: 6.051 Marco: 6.052 Marco: 6.054						

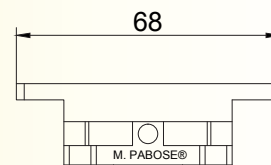
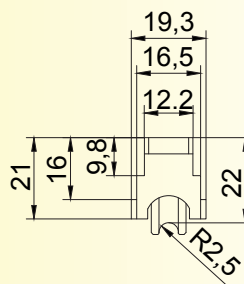

P-2002-A		Igual a la P-2002		2,50	Fijo Simple	Agujas	Zamak ZL5 Pintado Negro	40	80
-----------------	--	-------------------	--	------	-------------	--------	----------------------------	----	----

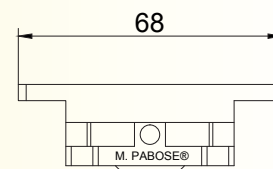
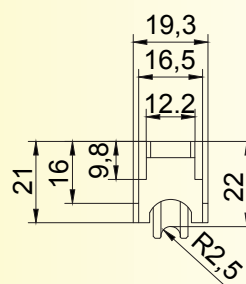
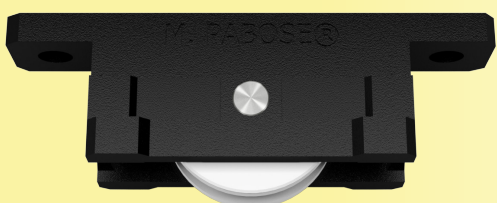

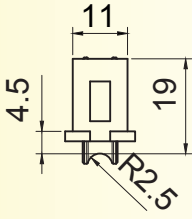
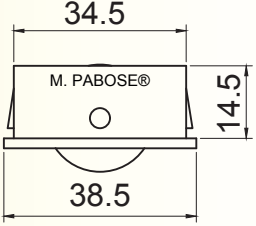
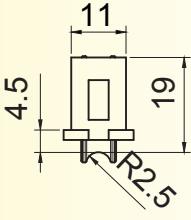
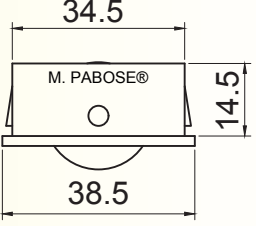
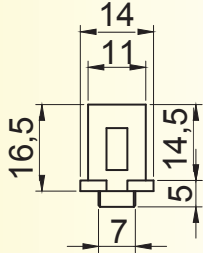
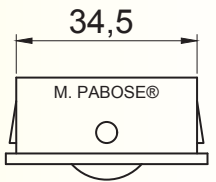
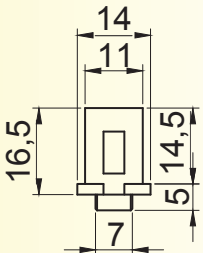
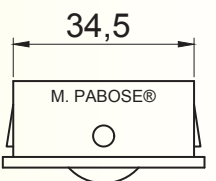
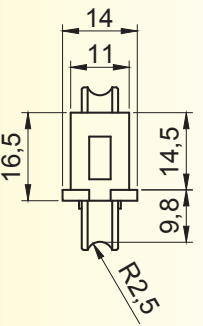
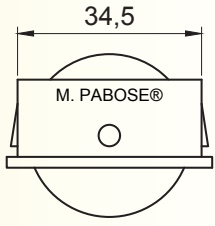
Referencia	Extrusor/Cliente	Serie	Perfil	Rueda radio/ang.	Tipo de Conjunto	Rodamiento	Soporte	Carga (Kg)	
								Rueda	Hoja
P-2011CH		Varias		2,50	Fijo Simple	Bolas	Poliamida 6/6 30% fibra de vidrio Color Blanco	15	30
		Cajeado 35,5 x 11,5 mm.							
P-2011CH-A		Varias		2,50	Fijo Simple	Agujas	Poliamida 6/6 30% fibra de vidrio Color Blanco	35	70
		Cajeado 35,5 x 11,5 mm.							
P-2011CH-01		Varias		Pista Plana 7	Fijo Simple	Bolas	Poliamida 6/6 30% fibra de vidrio Color Blanco	15	30
		Cajeado 35,5 x 11,5 mm.							
P-2011CH-01-A		Varias		Pista Plana 7	Fijo Simple	Agujas	Poliamida 6/6 30% fibra de vidrio Color Blanco	35	70
		Cajeado 35,5 x 11,5 mm.							
P-2011CH-02-A	Rehau	Meridian Design S-783	Hoja: 625.564 Hoja: 625.554 Marco: 625.534	2,50	Fijo Simple	Agujas	Poliamida 6/6 30% fibra de vidrio Color Blanco	40	80
		Cajeado 35,5 x 11,5 mm.							

Referencia	Extrusor/Cliente	Serie	Perfil	Rueda radio/ang.	Tipo de Conjunto	Rodamiento	Soporte	Carga (Kg)	
								Rueda	Hoja
T-15/12P-L	Azembla	Serie 2000	Hoja:ROY-205	Pista Plana 5,8	Fijo Simple	Rueda Latón	Poliamida 6/6 30% fibra de vidrio Color Blanco	7	14
		RBS 2000	Marco:ROY-201						
		Altavista	Marco:ROY-202						
		Azteca	Hoja:ROY-905 Marco:ROY-901						
	2000-Z	Hoja:ROY-105 Marco:ROY-101							
Tecnocom	Life	Hoja:ROY-1502 Maco:ROY-1501							

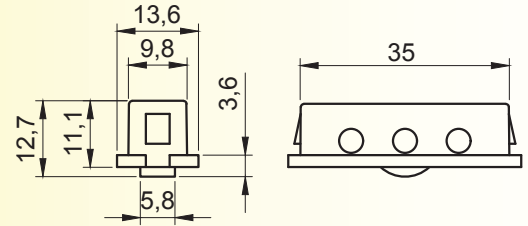

TT-15/12P-L		Igual a la T-15/12P-L		Pista Plana 5,8	Fijo Simple	Rueda Latón	Poliamida 6/6 30% fibra de vidrio Color Blanco	7	28
--------------------	--	-----------------------	--	-----------------------	-------------	----------------	--	---	----

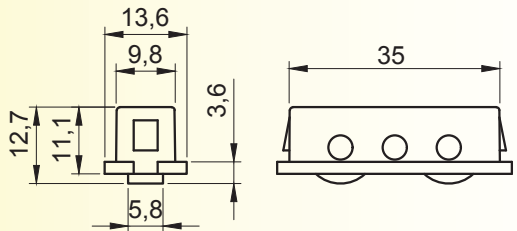
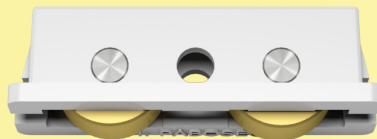

T-14036P	Tecnocom	Life 2		2,50	Fijo Simple	Bolas	Poliamida 6/6 Color Blanco	15	30
-----------------	----------	--------	--	------	-------------	-------	-------------------------------	----	----

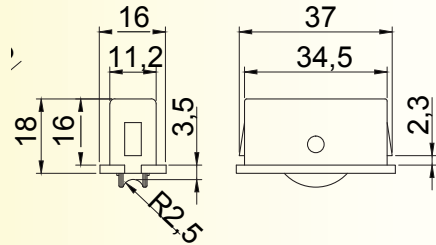

T-14036P-A	Tecnocom	Life 2		2,50	Fijo Simple	Agujas	Poliamida 6/6 Color Blanco	35	70
-------------------	----------	--------	--	------	-------------	--------	-------------------------------	----	----

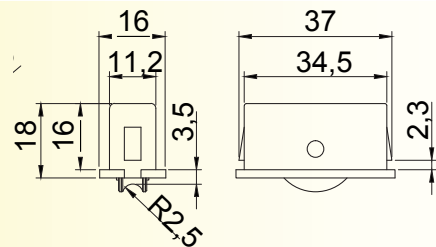

T-14036P-L	Tecnocom	Life 2		2,50	Fijo Simple	Rueda Latón	Poliamida 6/6 Color Blanco	15	30
-------------------	----------	--------	--	------	-------------	----------------	-------------------------------	----	----

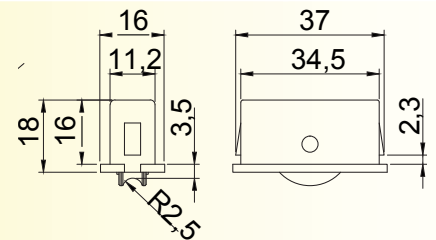
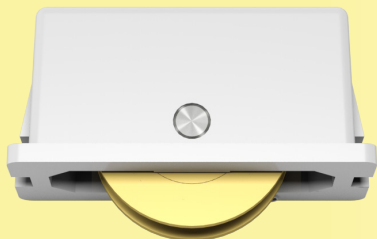

Referencia	Extrusor/Cliente	Serie	Perfil	Rueda	Tipo de	Soporte	Carga (Kg)		
				radio/ang.			Conjunto	Rodamiento	Rueda
P-17023-A	Varias		Mosquitero	Pista Plana 9,8	Fijo Simple	Agujas Acetal	Acero AP02 Zincado	15	30
P-17023E-A	Tecnocom	Eurolife							

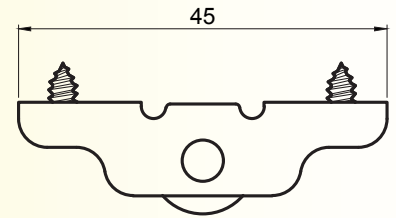
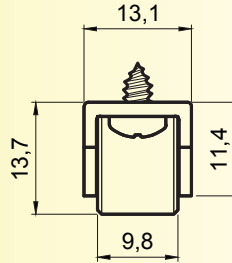
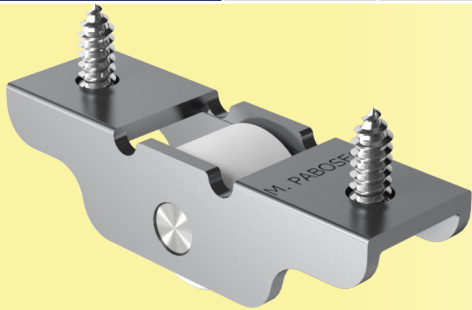

P-17023-AC	Varias		Mosquitero	Pista Plana 9,8	Fijo Simple	Sin Casquillo Acetal	Acero AP02 Zincado	7,5	15
P-17023E-AC	Tecnocom	Eurolife							

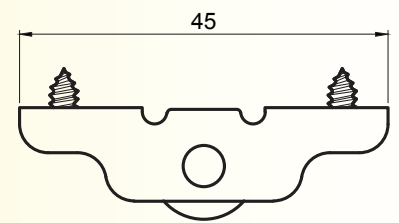
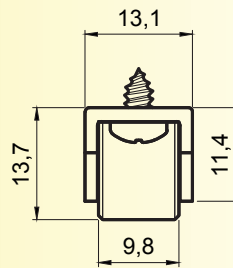
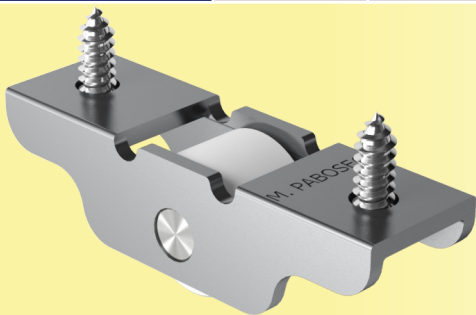

P-17024-A	Varias		Mosquitero	1,75	Fijo Simple	Agujas Acetal	Acero AP02 Zincado	15	30
------------------	--------	--	------------	------	-------------	---------------	--------------------	----	----

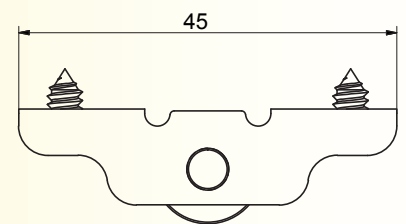
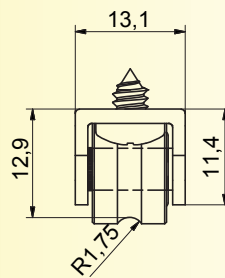
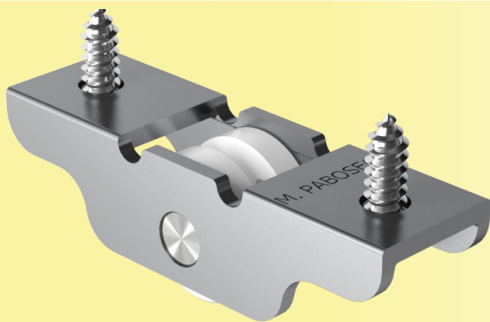

P-17024-AC	Varias		Mosquitero	1,75	Fijo Simple	Sin Casquillo Acetal	Acero AP02 Zincado	7,5	15
-------------------	--------	--	------------	------	-------------	----------------------	--------------------	-----	----

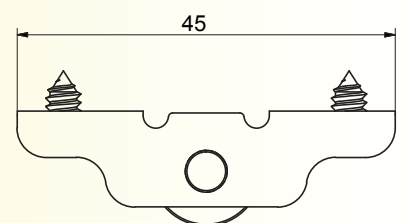
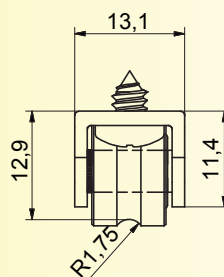
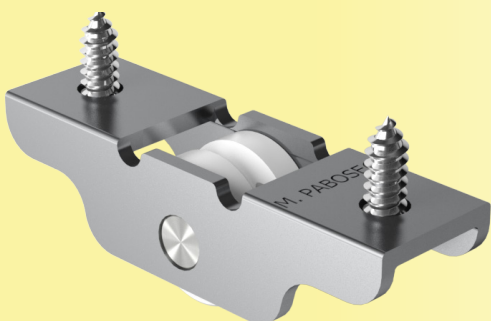

“Los tornillos de fijación se suministran en bolsa aparte”

M. Pabose® como fabricante del producto se reserva el derecho de efectuar sin previo aviso, las modificaciones que considere oportunas para mejorar las prestaciones de sus productos.

Referencia	Extrusor/Cliente	Serie	Perfil	Rueda radio/ang.	Tipo de Conjunto	Rodamiento	Soporte	Carga (Kg)	
								Rueda	Hoja
T-16003	Aluplast	SF-73	Hoja: 100x82 Marco: 100.080	2,50	Fijo Simple	Bolas	Acero AP02 Pintado Negro	15	30
		Sliding Windows 60	Hoja: 100374 Marco: 100.070						
	Kömmerling	Premiline	Hoja: 6.041 Marco: 6.050 Marco: 6.051 Marco: 6.052 Marco: 6.054						
	Archicentro		Hoja: 111						
	Rehau	Línea Exilis	Hoja: 500723 Marco: 500715						
Schüco		Hoja: 8830							

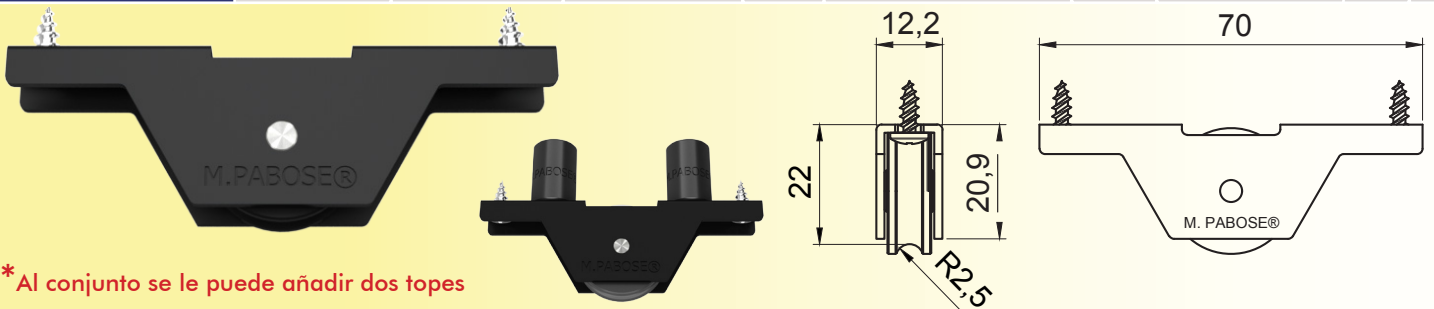

*Al conjunto se le puede añadir dos topes

T-16003-A	Igual a la T-16003			2,50	Fijo Simple	Agujas	Acero AP02 Pintado Negro	50	100
------------------	--------------------	--	--	------	-------------	--------	-----------------------------	----	-----

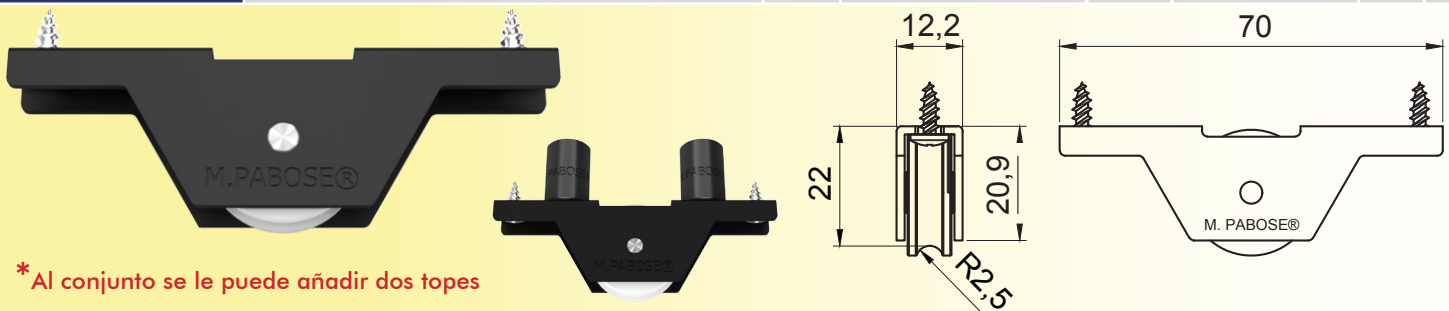

*Al conjunto se le puede añadir dos topes

T-16005	Varias			2,50	Fijo Simple	Bolas	Acero AP02 Pintado Negro	15	30
----------------	--------	--	--	------	-------------	-------	-----------------------------	----	----

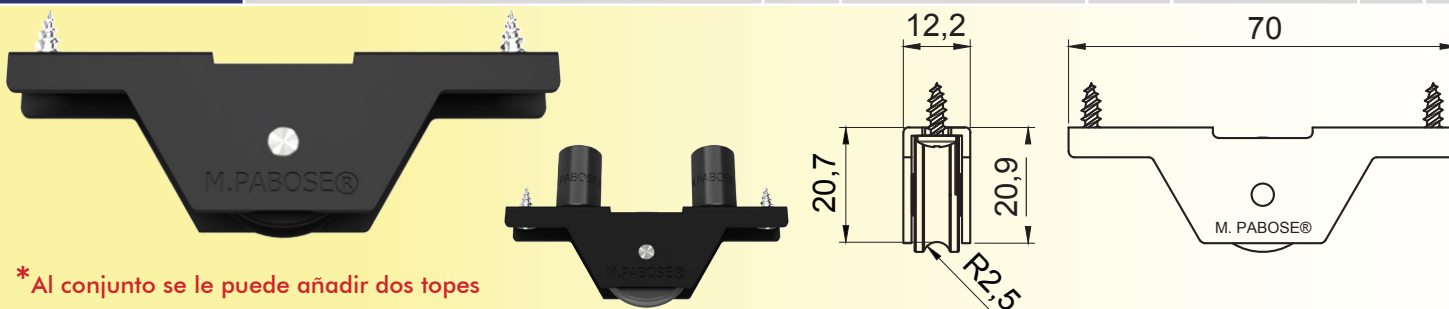

*Al conjunto se le puede añadir dos topes

T-16006-A	Varias			2,50	Fijo Simple	Agujas	Acero AP02 Pintado Negro	50	100
------------------	--------	--	--	------	-------------	--------	-----------------------------	----	-----

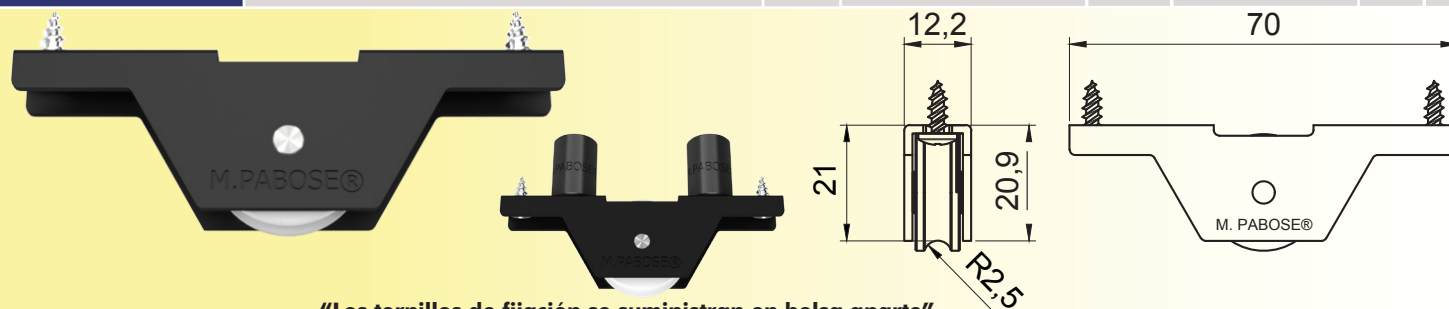

"Los tornillos de fijación se suministran en bolsa aparte"

*** IMPORTANTE:** Al conjunto, se le puede añadir dos topes fijados en los taladros de la parte superior del soporte, de medidas comprendidas entre 10,5 y 39,1 mm, para aumentar la altura en los casos que sean necesarios

Referencia	Extrusor/Cliente	Serie	Perfil	Rueda radio/ang.	Tipo de Conjunto	Rodamiento	Soporte	Carga (Kg)	
								Rueda	Hoja
T-16009-A		Winhouse		2,50	Fijo Simple	Agujas	Acero AP02 Pintado Negro	40	80

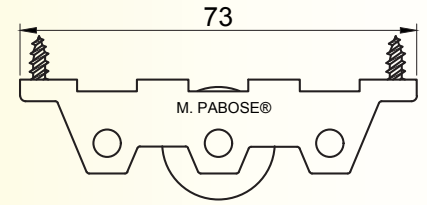
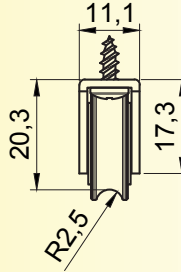

*Al conjunto se le puede añadir dos topes



TT-16009-A		Winhouse		2,50	Tándem Fijo	Agujas	Acero AP02 Pintado Negro	40	160
-------------------	--	----------	--	------	-------------	--------	-----------------------------	----	-----

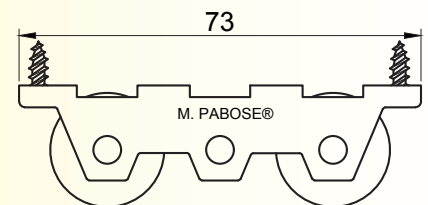
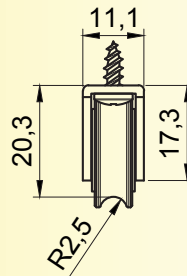
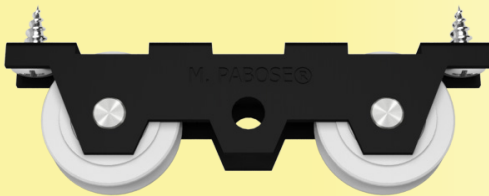

*Al conjunto se le puede añadir dos topes

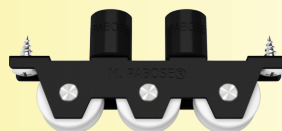

"Los tornillos de fijación se suministran en bolsa aparte"

*** IMPORTANTE:** A los conjuntos de dos y tres ruedas, se les puede añadir dos topes fijados en los taladros de la parte superior del soporte, de medidas comprendidas entre 10,5 y 39,1 mm, para aumentar la altura en los casos que sean necesarios

Referencia	Extrusor/Cliente	Serie	Perfil	Rueda	Tipo de	Soporte	Carga (Kg)		
				radio/ang.			Conjunto	Rodamiento	Rueda
T-15023X-A	PVTEC	Optima Perfil 71	Hoja:S-545.24 Marco:S-545.14	2,50	Fijo Simple	Agujas	Acero 304 Inoxidable	30	60
		Smartine	TL-85						
	Veka	Ekoline CR-58	Hoja: 105.712 Marco: 105.710						
		Softline	Hoja: 105.373						
	Royal Group	Sistema DC 62 mm	Hoja:ROY-1404 Hoja:ROY-1405 Marco:ROY-1401 Marco:ROY-1402						
		Calafate	Hoja:ROY-1911 Hoja:ROY-1902 Marco:ROY1901						
	Archicentro		Hoja: 66 y 88						
Kömmerring	Premiline 58	Hoja: 2174							

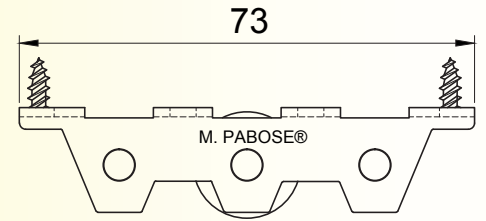
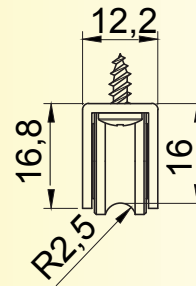

TT-15023X-A	Igual a la T-15023X-A			2,50	Tándem Fijo	Agujas	Acero 304 Inoxidable	30	120
-------------	-----------------------	--	--	------	-------------	--------	-------------------------	----	-----

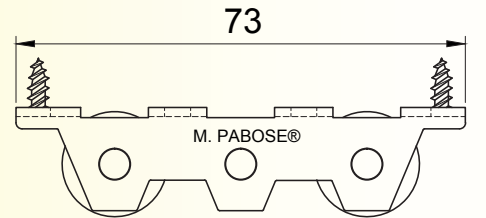
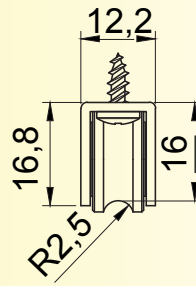

*Al conjunto se le puede añadir dos topes



TT3-15023X-A	Igual a la T-15023X-A			2,50	Fijo 3 Ruedas	Agujas	Acero 304 Inoxidable	30	180
--------------	-----------------------	--	--	------	---------------	--------	-------------------------	----	-----

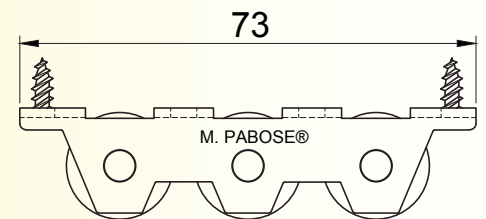
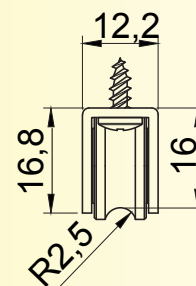
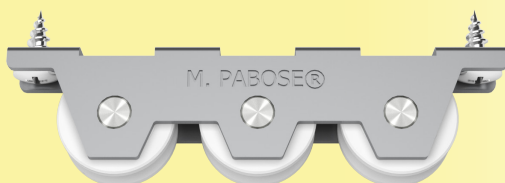

*Al conjunto se le puede añadir dos topes



"Los tornillos de fijación se suministran en bolsa aparte"

* **IMPORTANTE:** A los conjuntos de dos y tres ruedas, se les puede añadir dos topes fijados en los taladros de la parte superior del soporte, de medidas comprendidas entre 10,5 y 39,1 mm, para aumentar la altura en los casos que sean necesarios

Referencia	Extrusor/Cliente	Serie	Perfil	Rueda	Tipo de	Soporte	Carga (Kg)		
				radio/ang.			Conjunto	Rodamiento	Rueda
T-15024X-A	Kömmerling	Premiline	Hoja: 6.040 Marco: 6.050 Marco: 6.051 Marco: 6.052 Marco: 6.054	2,50	Fijo Simple	Agujas	Acero 304 Inoxidable	30	60
		SF3	Hoja: 1.396 Marco: 1.397						
	Aluplast	SF-60	Hoja: 100x72 Marco: 100.070						
	Rehau	920	Hoja: 500.033 Hoja: 500.043 Marco: 500.013						
		Línea Exilis	Hoja: 500.719 Marco: 500.715						
Veka	58-CD	Hoja: 105.378							

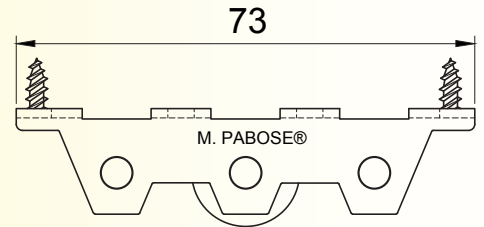
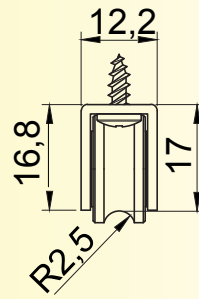

TT-15024X-A	Igual a la T-15024X-A			2,50	Tándem Fijo	Agujas	Acero 304 Inoxidable	30	120
-------------	-----------------------	--	--	------	-------------	--------	-------------------------	----	-----

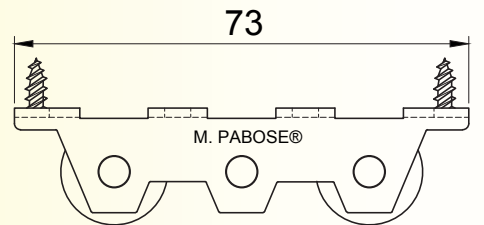
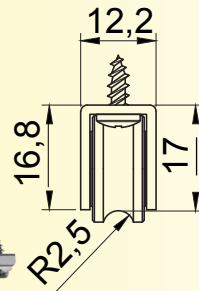

* Al conjunto se le puede añadir dos topes

TT3-15024X-A	Igual a la T-15024X-A			2,50	Fijo 3 Ruedas	Agujas	Acero 304 Inoxidable	30	180
--------------	-----------------------	--	--	------	---------------	--------	-------------------------	----	-----

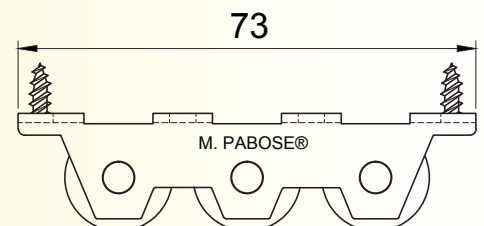
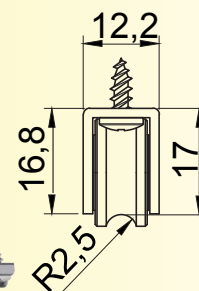

* Al conjunto se le puede añadir dos topes

"Los tornillos de fijación se suministran en bolsa aparte"

* **IMPORTANTE:** A los conjuntos de dos y tres ruedas, se les puede añadir dos topes fijados en los taladros de la parte superior del soporte, de medidas comprendidas entre 10,5 y 39,1 mm, para aumentar la altura en los casos que sean necesarios

Referencia	Extrusor/Cliente	Serie	Perfil	Rueda radio/ang.	Tipo de Conjunto	Rodamiento	Soporte	Carga (Kg)	
								Rueda	Hoja
T-15025X-A		Varias		2,50	Fijo Simple	Agujas	Acero 304 Inoxidable	30	60

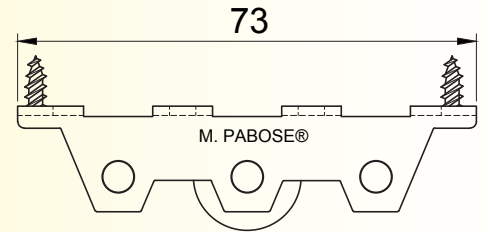
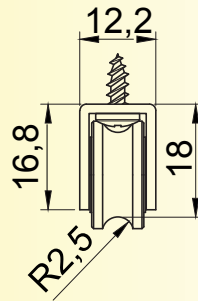

TT-15025X-A		Varias		2,50	Tándem Fijo	Agujas	Acero 304 Inoxidable	30	120
--------------------	--	--------	--	------	-------------	--------	-------------------------	----	-----

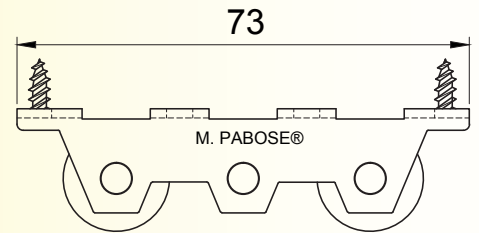
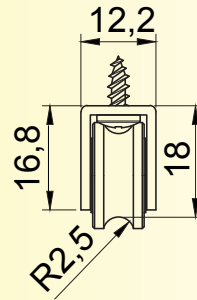

* Al conjunto se le puede añadir dos topes

TT3-15025X-A		Varias		2,50	Fijo 3 Ruedas	Agujas	Acero 304 Inoxidable	30	180
---------------------	--	--------	--	------	---------------	--------	-------------------------	----	-----

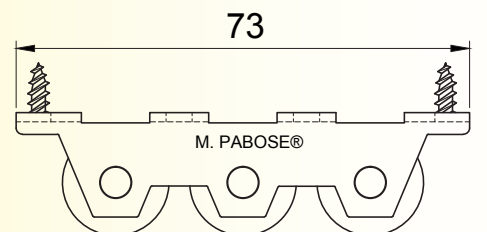
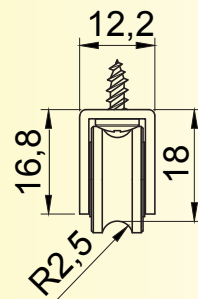
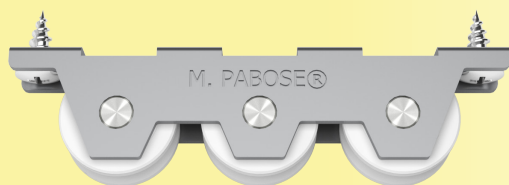

* Al conjunto se le puede añadir dos topes

"Los tornillos de fijación se suministran en bolsa aparte"

* **IMPORTANTE:** A los conjuntos de dos y tres ruedas, se les puede añadir dos topes fijados en los taladros de la parte superior del soporte, de medidas comprendidas entre 10,5 y 39,1 mm, para aumentar la altura en los casos que sean necesarios

Referencia	Extrusor/Cliente	Serie	Perfil	Rueda	Tipo de	Soporte	Carga (Kg)		
				radio/ang.	Conjunto		Rodamiento	Rueda	Hoja
T-15023X-S01-A		Varias		2,50	Fijo Simple	Agujas	Acero 304 Inoxidable	30	60

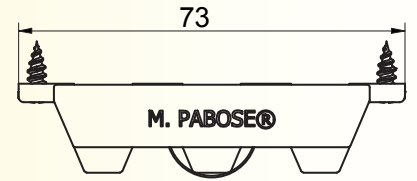
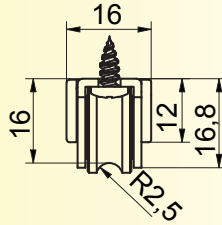

TT-15023X-S01-A		Varias		2,50	Tándem Fijo	Agujas	Acero 304 Inoxidable	30	120
------------------------	--	--------	--	------	-------------	--------	-------------------------	----	-----

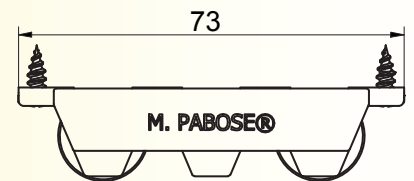
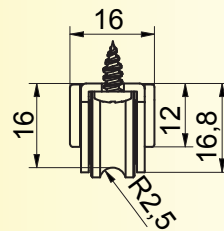

*Al conjunto se le puede añadir dos topes



TT3-15023X-S01-A		Varias		2,50	Fijo 3 Ruedas	Agujas	Acero 304 Inoxidable	30	180
-------------------------	--	--------	--	------	---------------	--------	-------------------------	----	-----

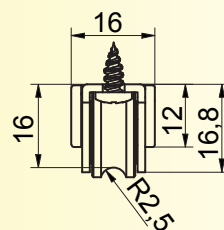

*Al conjunto se le puede añadir dos topes



"Los tornillos de fijación se suministran en bolsa aparte"

*** IMPORTANTE:** A los conjuntos de dos y tres ruedas, se les puede añadir dos topes fijados en los taladros de la parte superior del soporte, de medidas comprendidas entre 10,5 y 39,1 mm, para aumentar la altura en los casos que sean necesarios

Referencia	Extrusor/Cliente	Serie	Perfil	Rueda radio/ang.	Tipo de Conjunto	Rodamiento	Soporte	Carga (Kg)	
								Rueda	Hoja
T-15024X-S02-A	Exmet		Minimalista	2,50	Fijo Simple	Agujas	Acero 304 Inoxidable	30	60

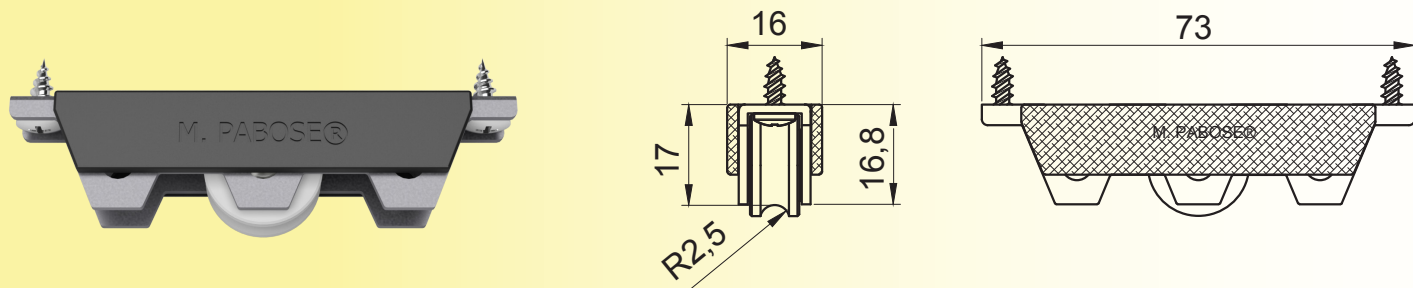

TT-15024X-S02-A	Exmet		Minimalista	2,50	Tándem Fijo	Agujas	Acero 304 Inoxidable	30	120
------------------------	-------	--	-------------	------	-------------	--------	-------------------------	----	-----

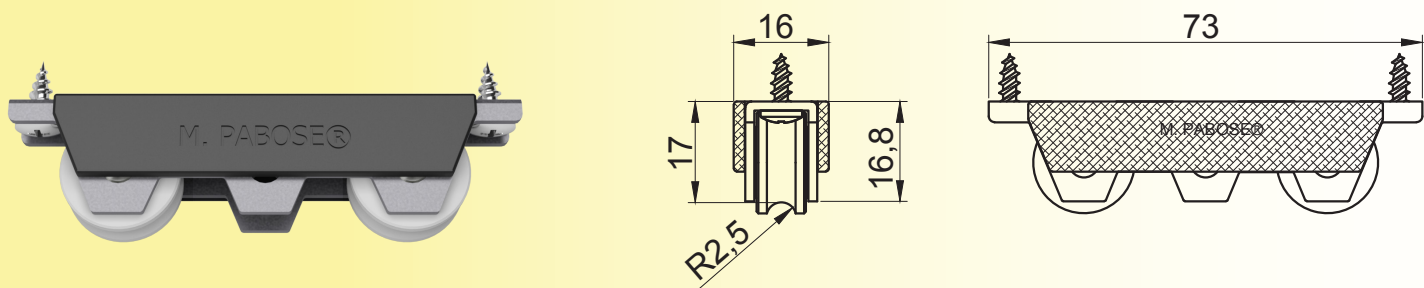

* Al conjunto se le puede añadir dos topes

TT3-15024X-S02-A	Exmet		Minimalista	2,50	Fijo 3 Ruedas	Agujas	Acero 304 Inoxidable	30	180
-------------------------	-------	--	-------------	------	---------------	--------	-------------------------	----	-----

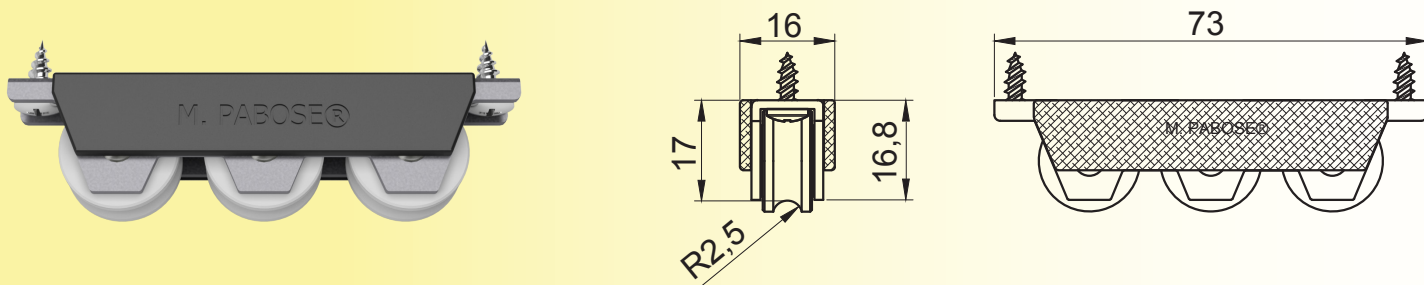

* Al conjunto se le puede añadir dos topes

"Los tornillos de fijación se suministran en bolsa aparte"

* **IMPORTANTE:** A los conjuntos de dos y tres ruedas, se les puede añadir dos topes fijados en los taladros de la parte superior del soporte, de medidas comprendidas entre 10,5 y 39,1 mm, para aumentar la altura en los casos que sean necesarios

Referencia	Extrusor/Cliente	Serie	Perfil	Rueda radio/ang.	Tipo de Conjunto	Rodamiento	Soporte	Carga (Kg)	
								Rueda	Hoja
T-15025X-S01-A		Varias		2,50	Fijo Simple	Agujas	Acero 304 Inoxidable	30	60

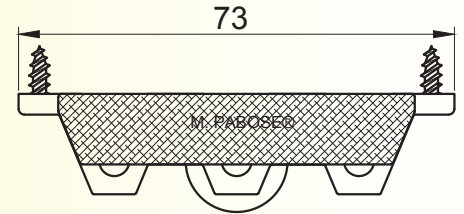
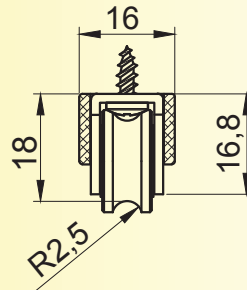

TT-15025X-S01-A		Varias		2,50	Tándem Fijo	Agujas	Acero 304 Inoxidable	30	120
------------------------	--	--------	--	------	-------------	--------	-------------------------	----	-----

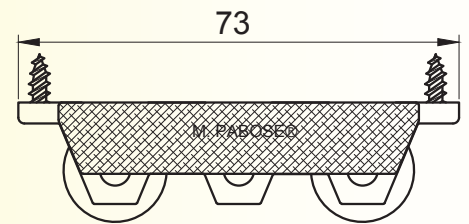
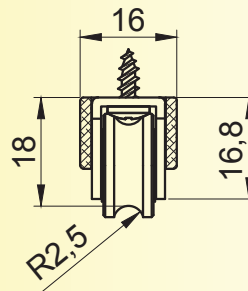

* Al conjunto se le puede añadir dos topes



TT3-15025X-S01-A		Varias		2,50	Fijo 3 Ruedas	Agujas	Acero 304 Inoxidable	30	180
-------------------------	--	--------	--	------	---------------	--------	-------------------------	----	-----

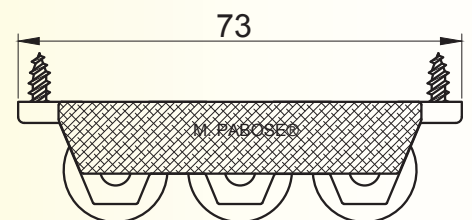
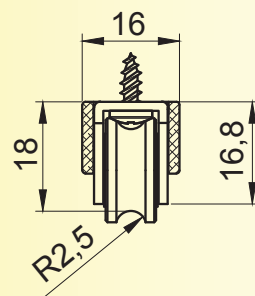

* Al conjunto se le puede añadir dos topes



"Los tornillos de fijación se suministran en bolsa aparte"

*** IMPORTANTE:** A los conjuntos de dos y tres ruedas, se les puede añadir dos topes fijados en los taladros de la parte superior del soporte, de medidas comprendidas entre 10,5 y 39,1 mm, para aumentar la altura en los casos que sean necesarios

Referencia	Extrusor/Cliente	Serie	Perfil	Rueda radio/ang.	Tipo de Conjunto	Rodamiento	Soporte	Carga (Kg)	
								Rueda	Hoja
TP-17002-A		Varias		2,50	Tándem Fijo Basculante	Agujas	Acero AP02 Pintado Negro	15	60

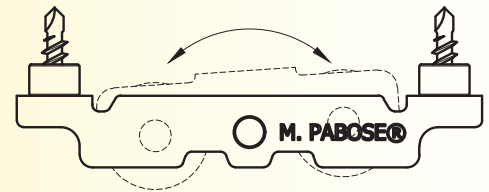
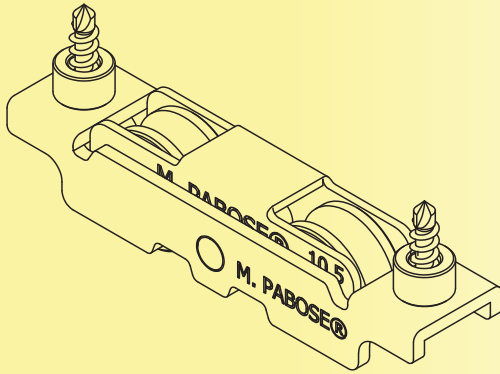
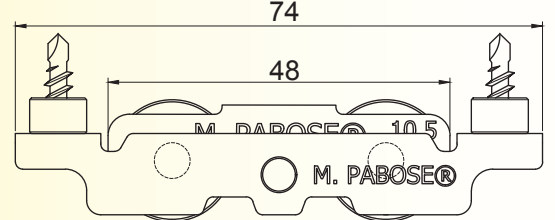
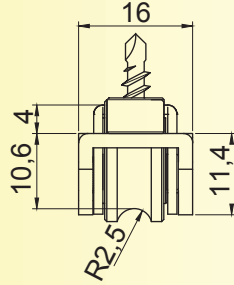

BASCULANTE

TP-17003-A		Varias		2,50	Tándem Fijo Basculante	Agujas	Acero AP02 Pintado Negro	15	60
-------------------	--	--------	--	------	---------------------------	--------	-----------------------------	----	----

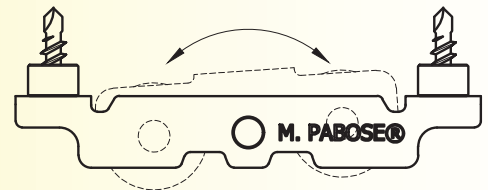
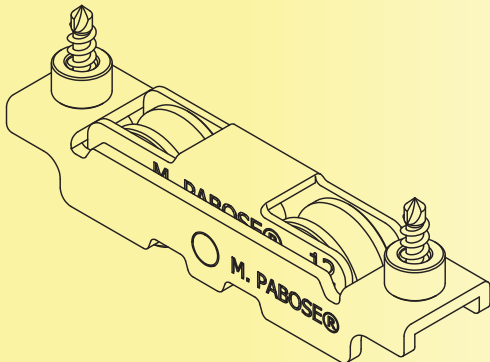
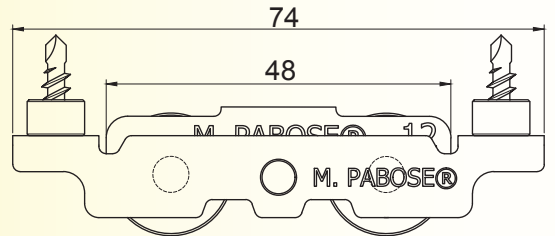
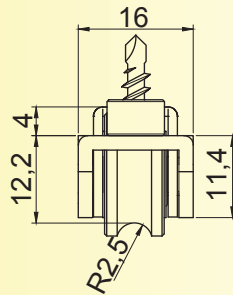

BASCULANTE

“Los topes de poliamida y los tornillos de fijación se suministran en bolsa aparte”
M. Pabose® como fabricante del producto se reserva el derecho de efectuar sin previo aviso, las modificaciones que considere oportunas para mejorar las prestaciones de sus productos.

Referencia	Extrusor/Cliente	Serie	Perfil	Rueda	Tipo de		Carga (Kg)		
				radio/ang.	Conjunto	Rodamiento	Soporte	Rueda	Hoja
T-15/26-A	PVTEC	Optima Perfil 71	Hoja:S-545.24 Marco:S-545-14	2,50	Fijo Simple	Agujas	Acero AP02 Pintado Negro	50	100
	Rehau	S-717	Hoja:557.091 Marco:557.000						
	Salamander Desing ID	Jetline	Hoja:611.020 Marco:610.040						

Cajetin 12,7x 70,5 mm.
Excepto Salamander

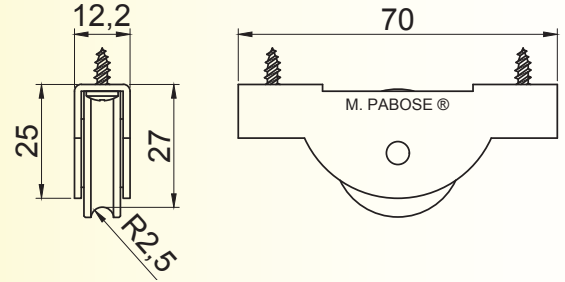

GT-20/40	Veka	PD-10	Hoja:SR-1175 Marco:PD-1014	2,60	Simple Graduable Desmontable	Bolas	Zamak ZL5 Pintado Negro	25	50
		Slimline 10							
	Finstral	System 900							
	Azembra	Panorama							

Se entrega con tornillos Inox. de fijación Montados

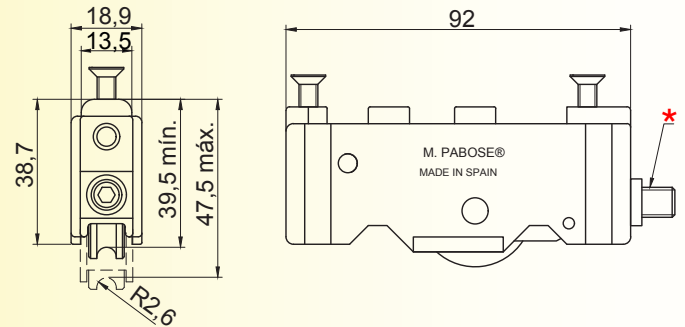
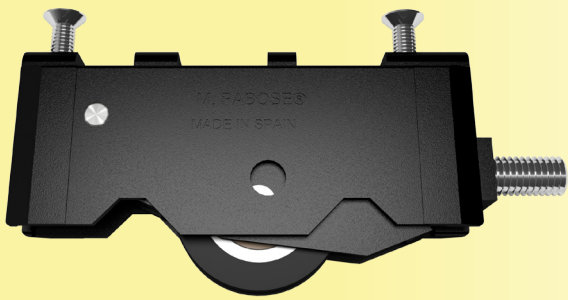

GT-20/40-A	Igual a la GT-20/40			2,60	Simple Graduable Desmontable	Agujas	Zamak ZL5 Pintado Negro	70	140
------------	---------------------	--	--	------	---------------------------------	--------	----------------------------	----	-----

Se entrega con tornillos Inox. de fijación Montados

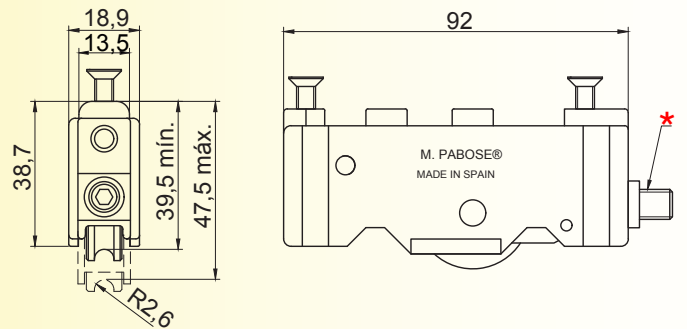
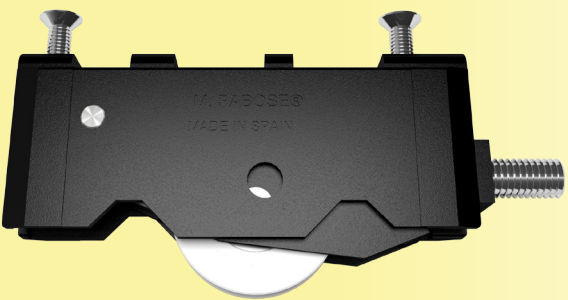

TT-28/1-E-A	Varias			3	Tándem Fijo Basculante	Agujas	Acero AP02 Pintado Negro	60	240
-------------	--------	--	--	---	---------------------------	--------	-----------------------------	----	-----

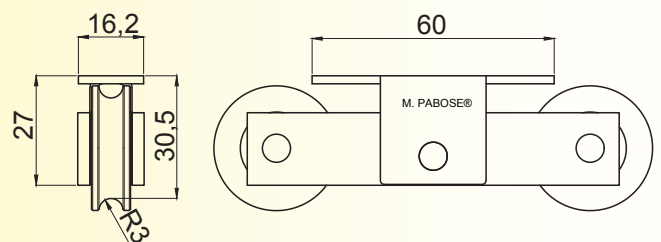
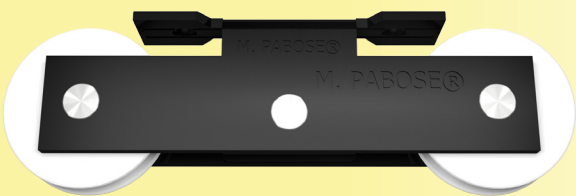

* Espárrago que va frenado para mantener fija la regulación.

M. Pabose® como fabricante del producto se reserva el derecho de efectuar sin previo aviso, las modificaciones que considere oportunas para mejorar las prestaciones de sus productos.

COLOCACIÓN TORNILLOS DE FIJACIÓN

1

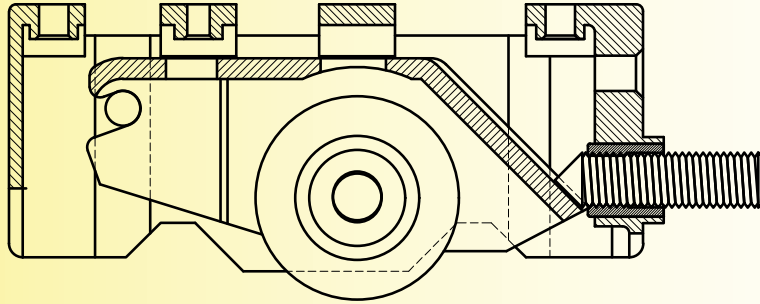

2

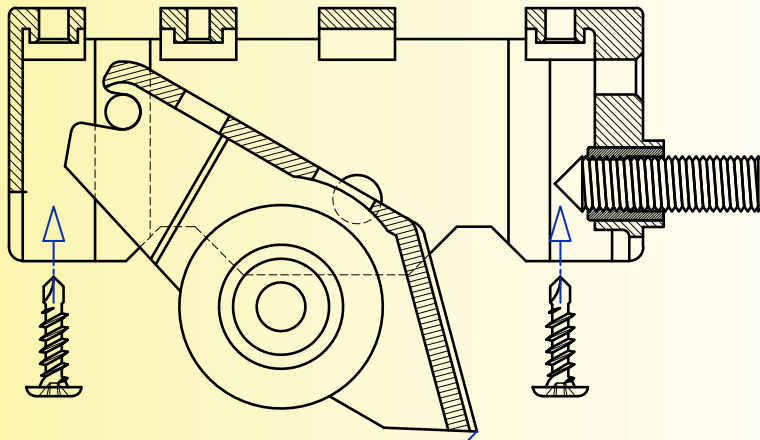

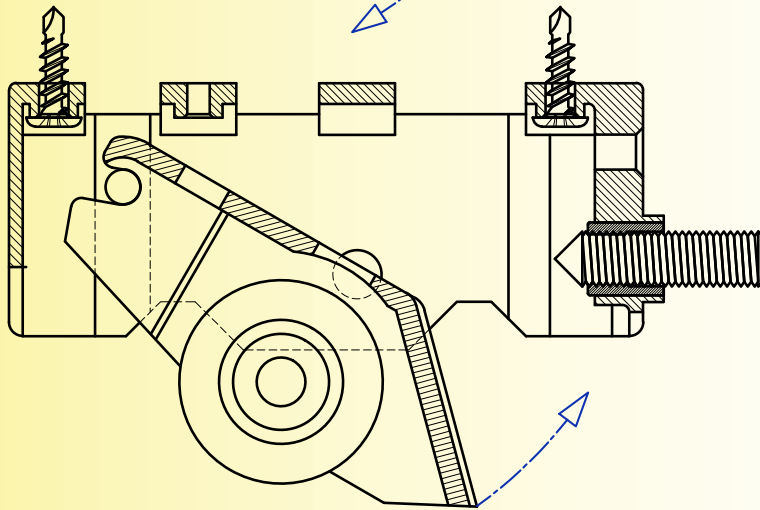

3

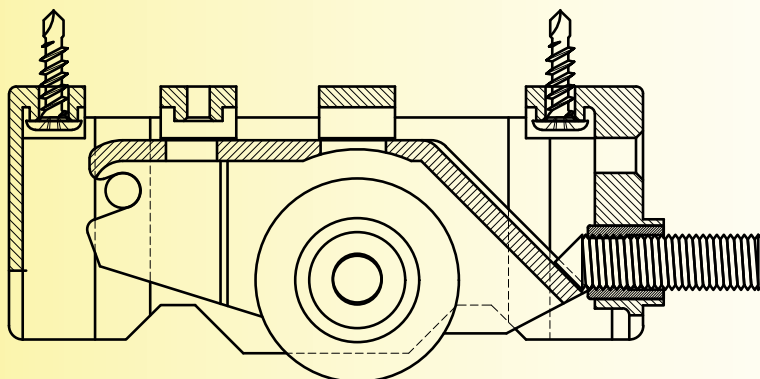

4



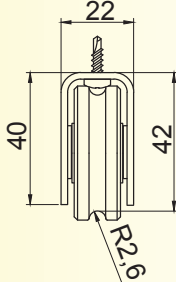
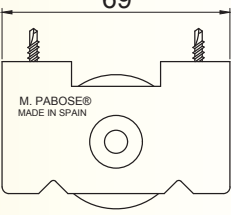

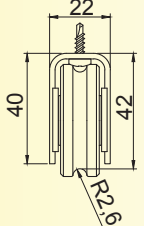
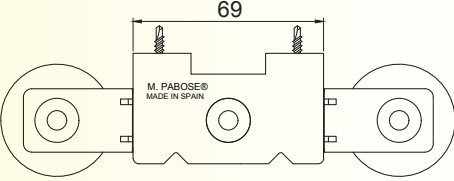
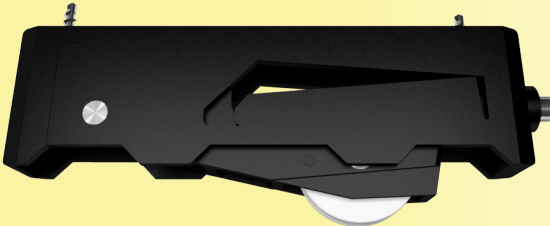
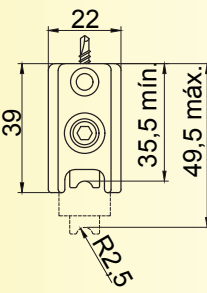
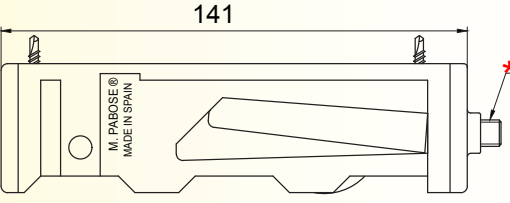
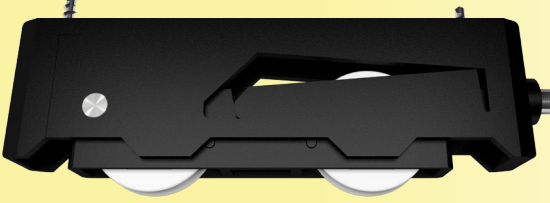
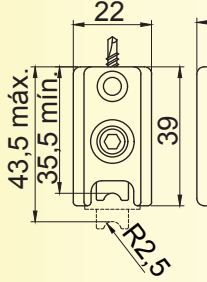
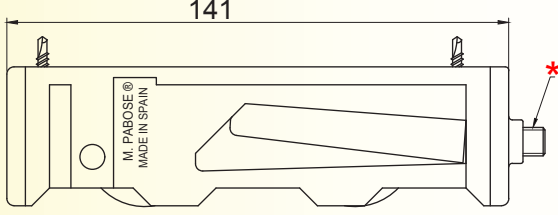
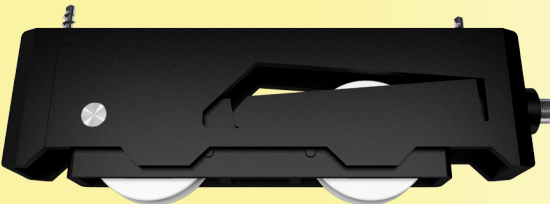
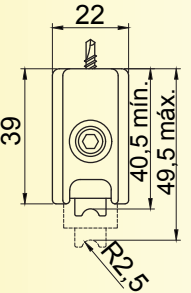
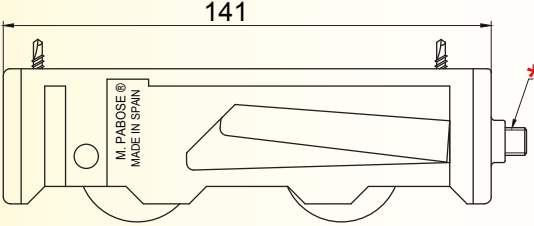
¡¡¡IMPORTANTE! Para garantizar la carga el radio de la rueda debe coincidir con el radio del riel (2,5 mm.)

Referencia	Extrusor/Cliente	Serie	Perfil	Rueda	Tipo de	Soporte	Carga (Kg)		
				radio/ang.			Conjunto	Rodamiento	Rueda
T-220/390-A	Varias			2,60	Fijo Simple	Agujas	Acero AP02 Pintado Negro	100	200
	Sistemas de Aluminio y PVC, canal de 22 mm. iii NO ELEVABLE!!!								
									
TT-220-390-A	Igual a la T-220/390-A			2,60	Tandem Fijo Basculante	Agujas	Acero AP02 Pintado Negro	100	400
									
GT-220/390-A	Varias			2,50	Simple Graduable Desmontable	Agujas	Zamak ZL5 Pintado Negro	100	200
	Sistemas de Aluminio y PVC, canal de 22 mm. iii NO ELEVABLE!!!								
									
GTT-220/390-A	Igual a la GT-220/390-A			2,50	Tándem Graduable Basculante y Desmontable	Agujas	Zamak ZL5 Pintado Negro	100	400
									
GTT-220/390-02-A	Varias			2,50	Tándem Graduable Basculante y Desmontable	Agujas	Zamak ZL5 Pintado Negro	100	400
	Sistemas de Aluminio y PVC, canal de 22 mm. iii NO ELEVABLE!!!								
									

*Espárrago que va frenado para mantener fija la regulación. "Los tornillos de fijación se suministran en bolsa aparte"
M. Pabose® como fabricante del producto se reserva el derecho de efectuar sin previo aviso, las modificaciones que considere oportunas para mejorar las prestaciones de sus productos.

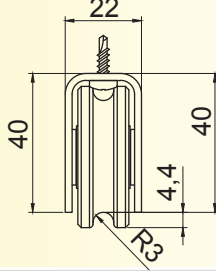
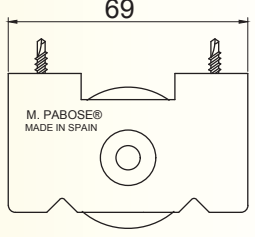
¡IMPORTANTE! Para garantizar la carga el radio de la rueda debe coincidir con el radio del riel (3,0 mm.)

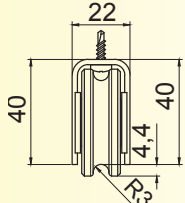
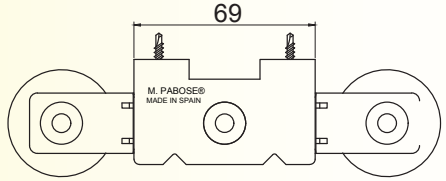
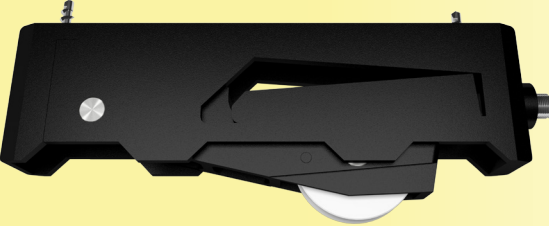
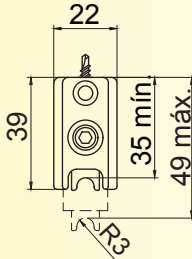
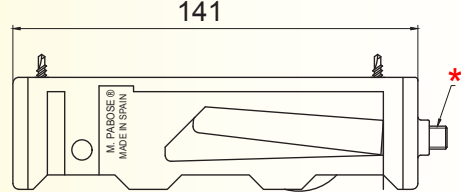
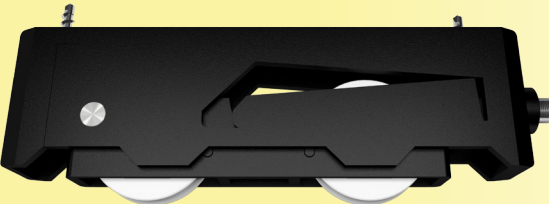
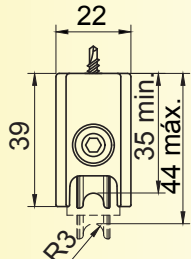
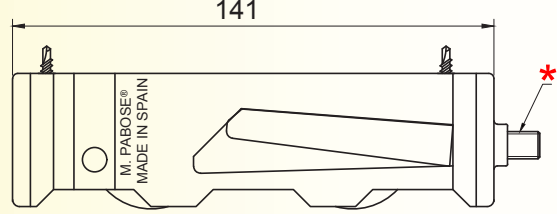
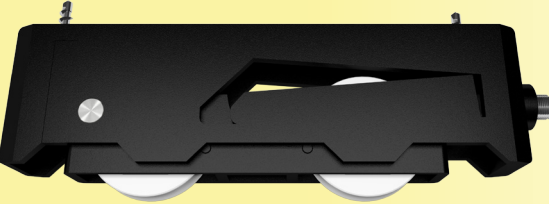
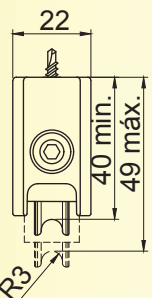
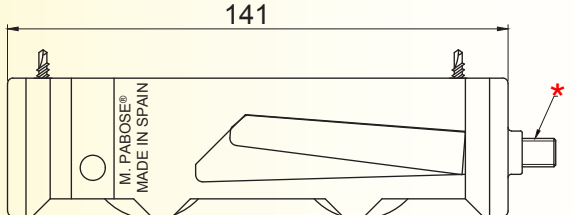
Referencia	Extrusor/Cliente	Serie	Perfil	Rueda radio/ang.	Tipo de Conjunto	Tipo de Rodamiento	Soporte	Carga (Kg) Rueda Hoja
R-34/3-A		Varias Sistemas de Aluminio y PVC, canal de 22 mm. iii NO ELEVABLE!!!		3,00	Fijo Simple	Agujas	Acero AP02 Pintado Negro	125 250
								
T-R34/3-A		Igual a la R-34/3-A		3,00	Tandem Fijo Basculante	Agujas	Acero AP02 Pintado Negro	125 500
								
G-R34/3-A		Varias Sistemas de Aluminio y PVC, canal de 22 mm. iii NO ELEVABLE!!!		3,00	Simple Graduable Desmontable	Agujas	Zamak ZL5 Pintado Negro	125 250
								
GT-R34/3-A		Igual a la G-R34/3-A		3,00	Tándem Graduable Basculante y Desmontable	Agujas	Zamak ZL5 Pintado Negro	125 500
								
GT-R34/3-02-A		Varias Sistemas de Aluminio y PVC, canal de 22 mm. iii NO ELEVABLE!!!		3,00	Tándem Graduable Basculante y Desmontable	Agujas	Zamak ZL5 Pintado Negro	125 500
								

*Espárrago que va frenado para mantener fija la regulación. "Los tornillos de fijación se suministran en bolsa aparte"
M. Pabose® como fabricante del producto se reserva el derecho de efectuar sin previo aviso, las modificaciones que considere oportunas para mejorar las prestaciones de sus productos.

Referencia	Extrusor/Cliente	Serie	Perfil	Rueda radio/ang.	Tipo de Conjunto	Rodamiento	Soporte	Carga (Kg) Rueda Hoja	
G-120/180-A	VER RELACIÓN SERIES / PERFILES EN TABLA ANEXA 1 Este producto no admite Topes			2,50	Simple Graduable y Desmontable	Agujas	Zamak ZL5 Pintado Negro Tirante INOX.	35	70

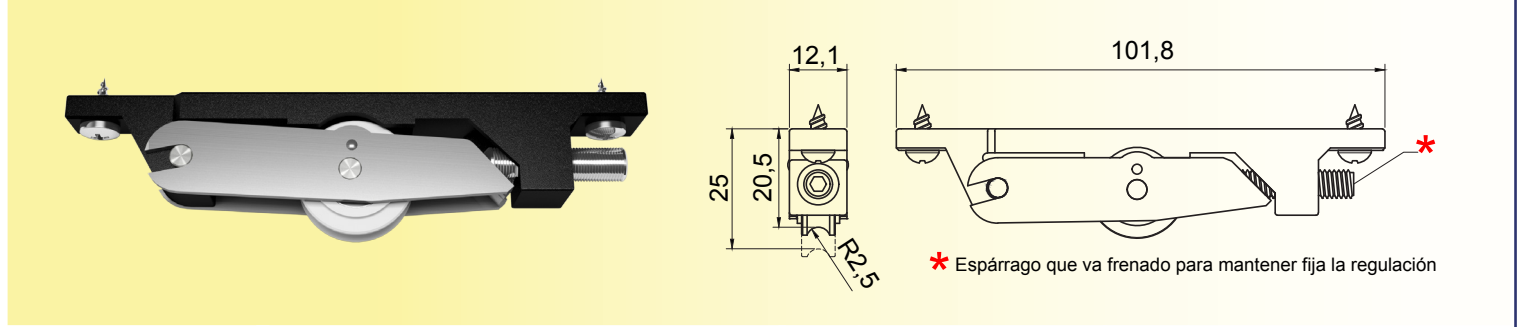

GT-1004/4-T-E-A	VER TABLA ANEXA 1 Al conjunto se le puede añadir topes de medidas comprendidas entre 10,5 y 39,1 mm para aumentar la altura en los casos que sea necesario. (Suministrados en Bolsa a parte)			2,50	Tándem Graduable	Agujas	Acero 304 Inoxidable	35	140
------------------------	--	--	--	------	---------------------	--------	-------------------------	----	-----

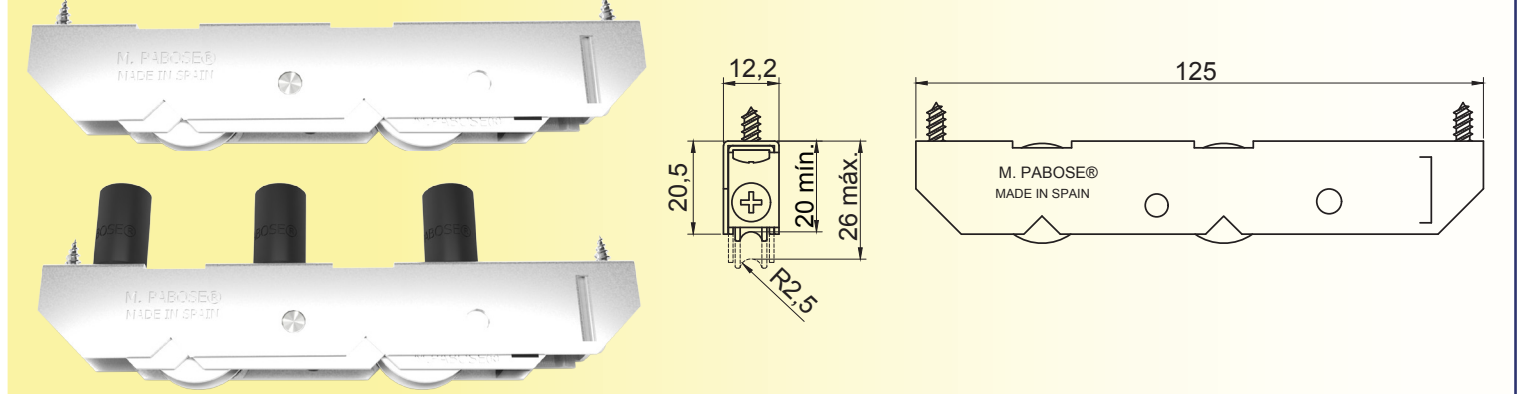

GT-1004/4-KM-TE-A	Kömmerring	SF2-A	Hoja:P1386 Hoja:P1391KTK Marco:P1998 Marco:P0385 Marco:P0386 Marco:P0387	2,50	Tándem Graduable	Agujas	Acero 304 Inoxidable	35	140
--------------------------	------------	-------	---	------	---------------------	--------	-------------------------	----	-----

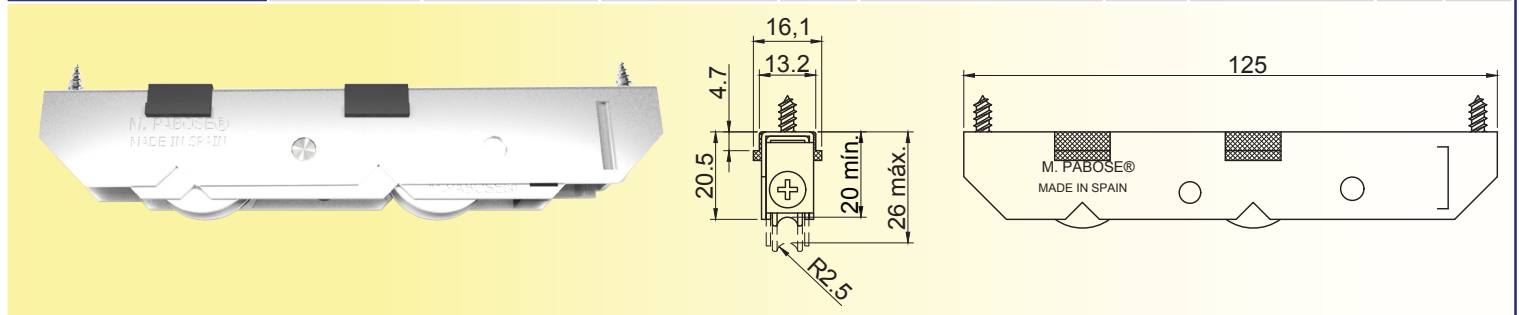

GT-1004/4-S01-A	Salamander Designe ID	Jetline	Hoja: 611.020 Marco:610.040	2,50	Tándem Graduable	Agujas	Acero 304 Inoxidable	35	140
------------------------	--------------------------	---------	--------------------------------	------	---------------------	--------	-------------------------	----	-----

c/ Suplem. ABS GT-1004/4 116 x 12,2 x 4

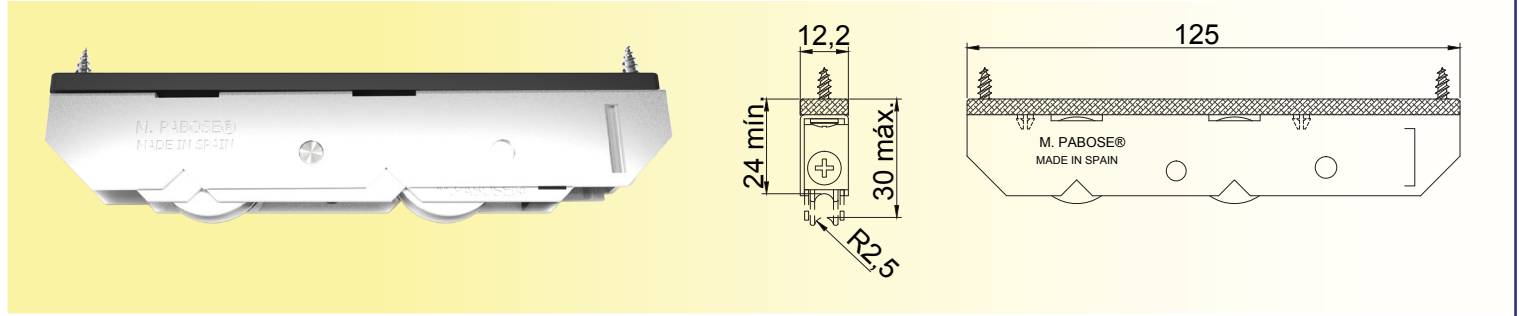

“Los tornillos de fijación se suministran en bolsa aparte”

M. Pabose® como fabricante del producto se reserva el derecho de efectuar sin previo aviso, las modificaciones que considere oportunas para mejorar las prestaciones de sus productos.

TABLA ANEXA 1

EXTRUSOR	SERIES	PERFILES	TOPE (Altura)	EXTRUSOR	SERIES	PERFILES	TOPE (Altura)	
A.G.B	Ekosol-90	Hoja:105.312 Marco:105.310	28,8 mm.	KÖMMERLING	Premiline	Hoja: 6.041 Marco: 6.050 Marco: 6.051 Marco: 6.052 Marco: 6.054	23,2 mm.	
ALPHACAN	Línea PSF	Hoja: E-4120 Marco: E-4100	Sin Tope		Orta		Hoja: P1683 Marco: P1661 Marco: P1667 Marco: P1673 Marco: P1678	18,0 mm.
	Refuerzo: 1069/1070/1071	Hoja:97414 Marco:97401	Sin Tope			SF2-H 300	Hoja: P1945 Marco: P0386	13,0 mm.
ALUPLAST	SF-73	Hoja:00x82 Marco:100.080	16,5 mm.			Premiline 68	Hoja: 2173 Hoja: 2174	18,0 mm.
	SF-80	Hoja:100x93 Marco:100.090		SALAMANDER	Sistema Inline SF	Hoja: 641.028 Marco:640.028	13,0 mm.	
	Sliding 60 Refuerzo:229006	Hoja: 100374 Marco:100070	23,2 mm.		Deslizante 74 Refuerzo 601028	Hoja: 601.028 Marco:600.028	Sin Tope	
		Hoja: 100074 Marco:100069	Solo GT-1004/4-TE-A		Evolution Drive	Hoja: 601.128 Marco:600.128	Sin Tope	
	Multisliding 96 Refuerzo:209092/ 209093	Hoja: 100x93 Marco: 100097		16,5 mm.	Hoja Grande	Hoja: 601.138 Marco:600.128	26,3 mm.	
ARCHICENTRO		Hoja: 111				17,0 mm.		
AZEMBLA	Sistema DC 62 mm.	Hoja:ROY-1404 Marco:ROY-1401 Marco:ROY-1402	27,8 mm.	SCHÜCO	Corona S-74	Hoja: 8.857 Marco: 8.856	18,0 mm.	
DECEUNNINCK	Monorail Zendow	Hoja: 3.410 Marco: 3.400	13,0 mm.	PVTEC	Optima Perfil 78	Hoja:S-545.12 Marco:S-545.14	13,0 mm.	
	Bella	Hoja: 12471 Marco: 12987			Optima Perfil 93	Hoja:S-545.13 Marco:S-545.14	27,8 mm.	
DIMEX	System Perfekt 70mm	Hoja:611.000 Marco:610.900	17,0 mm.					
FINSTRAL	System 900		Sin Tope					
GEALAN		Hoja: 3031-68 Hoja: 3031-69 Marco:3030	19,0 mm.					
		Hoja: 3083-62 Hoja: 3083-63 Marco:3029-24		Sin Tope				
	SF-74	Hoja: 5803 Marco:5802	23,2 mm.					
GLASSTECH		Hoja: SF-66 Marco: HF-62	Sin Tope					

No admite Tope

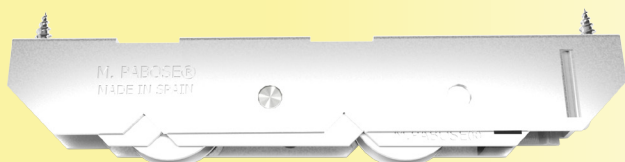
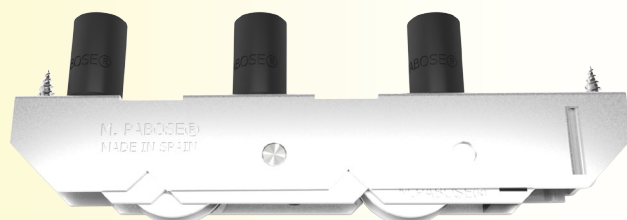

M. Pabose® como fabricante del producto se reserva el derecho de efectuar sin previo aviso, las modificaciones que considere oportunas para mejorar las prestaciones de sus productos.

TABLA ANEXA 1

EXTRUSOR	SERIES	PERFILES	TOPE (Altura)
REHAU	920-HD	Hoja: 500486 Hoja: 510486	20,0 mm
	920-SA	Marco: 500086 Marco: 510086 Marco: 520086	
	Línea Exilis	Hoja: 500723 Marco: 500715	16,5 mm
	Highdesign Slide		20,0 mm
	EuroSlide-920	Hoja: 500403 Marco: 500013	
TECNOCOM	DZ 89-46 Refuerzo PR-2009	Hoja: PH1010 Marco: PM1250	26,3 mm.
	DZ 89-46 Refuerzo PR-2009/1	Marco: PM1260 Marco: AU4032	25,0 mm.
	DZ 89-46 Refuerzo PR-2010	Hoja: PH1011 Marco: PM1250 Marco: PM1260	Sin Tope
	DZ 74-36 Refuerzo PR-2010	Hoja: PH1012 Marco: PM1240 Marco: PM1241	Sin Tope
	Línea Advance		Sin Tope
	Línea Prime		26,3 mm.
VEKA	Ekosol-70	Hoja: 105.321 Marco: 105.351	28,8 mm.
	Nova Ekosol	Hoja: 105.321 Hoja: 105.322 Marco: 105.351	28,8 mm.
	Euroslide-70		
	CR-70		
	Softline CR-73	Hoja: 105.715 Marco: 105.701	22,1 mm.
	Ekosol-89	Hoja: 105.241 Marco: 105.245 Marco: 105.270	26,3 mm.
	Sistema DS01	Hoja: PH1012 Marco: PM1241	Sin Tope
		Hoja: SI-0138 Sin Refuerzo	Sin Tope
Ekosol H-74	Hoja: 105.241 Marco: 105.245 Marco: 105.720	26,3 mm.	

No admite tope

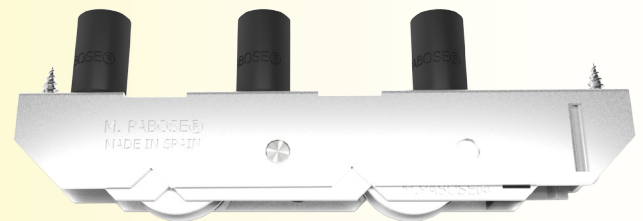
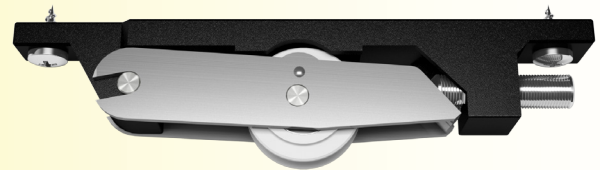

Referencia	Extrusor/Cliente	Serie	Perfil	Rueda radio/ang.	Tipo de Conjunto	Rodamiento	Soporte	Carga (Kg)	
								Rueda	Hoja
GTT-15001-HK-A	VER RELACIÓN SERIES / PERFILES EN TABLA ANEXA 2			2,50	Tándem Graduable	Agujas Protección Anticorrosiva	Acero 304 Inoxidable	70	280
	Al conjunto se le puede añadir topes de medidas comprendidas entre 10,5 y 39,1 mm para aumentar la altura en los casos que sea necesario. (Suministrados en Bolsa a parte)								



Tabla Anexa 2			
EXTRUSOR	SERIES	PERFILES	Tope (altura)
ALUPLAST	SF-60	Hoja: 100374 Marco: 10070	23,2 mm
	SF-73	Hoja: 100x82 Marco: 100080	16,5 mm
	SF-80	Hoja: 100x93 Marco: 10090	16,5 mm
	Multi Sliding-96	Hoja: 100x93 Marco: 10097	16,5 mm
DECEUNINCK	Surme Sliding (Puerta refuerzo 1,4 mm)	Hoja: 12671 Marco: 12660	22,1 mm
	Surme Sliding (Puerta refuerzo 2,0 mm)	Hoja: 12671 Marco: 12660	22,1 mm
REHAU	920-HD	Hoja: 500486 Hoja: 510486	20,0 mm
	920-SA	Marco: 500086 Marco: 510086 Marco: 520086	

Tabla Anexa 2			
EXTRUSOR	SERIES	PERFILES	Tope (altura)
VEKAPLAST	Ekosol-70	Hoja: 105322 Marco: 105351	13,0 mm
		Hoja: 105322 Marco: 105351 Hoja: 105321 Marco: 105351	28,8 mm
	Softline CR-73	Hoja: 105715 Marco: 105701	22,1 mm
	Ekosol H-89	Hoja: 105241 Marco: 105720	26,3 mm
SCHÜCO	Corona S-74	Hoja: 8857 Marco: 8856	19,0 mm
	Winhouse		33,2 mm

“Los tornillos de fijación se suministran en bolsa aparte”

M. Pabose® como fabricante del producto se reserva el derecho de efectuar sin previo aviso, las modificaciones que considere oportunas para mejorar las prestaciones de sus productos.

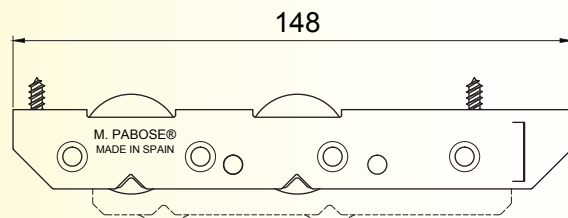
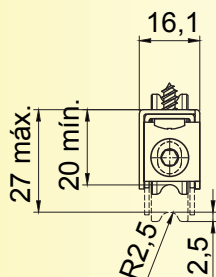
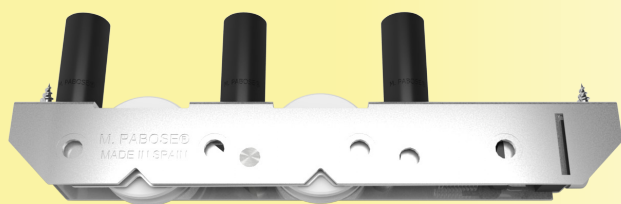
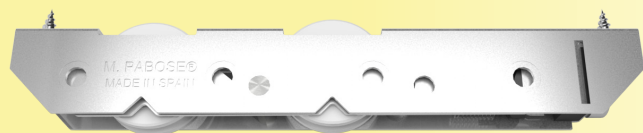
Referencia	Extrusor/Cliente	Serie	Perfil	Rueda radio/ang.	Tipo de Conjunto	Tipo de Rodamiento	Soporte	Carga (Kg)	
								Rueda	Hoja
GTT-17008-HK-A	Tecnocom	Línea Jumbo		3,30	Tándem Graduable	Agujas Protección Anticorrosiva	Acero 304 Inoxidable	75	300
								Con Topes de 39,1 mm	

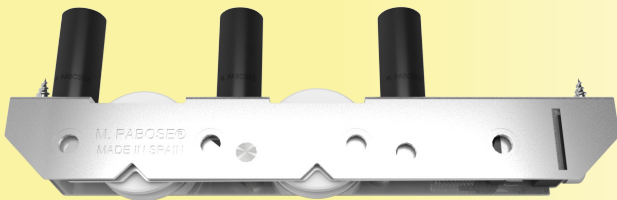
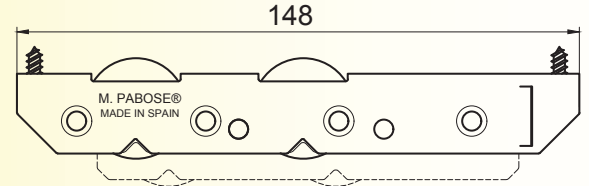
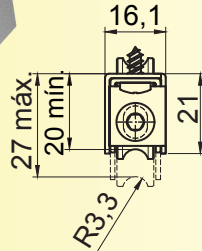
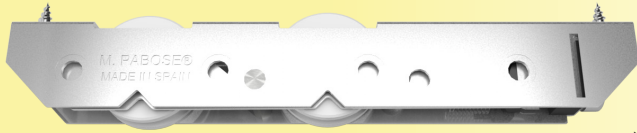

Para otras series al conjunto se le puede añadir topes de medidas comprendidas entre 10,5 y 39,1 mm para aumentar la altura en los casos que sea necesario. (Suministrados en Bolsa a parte)

GTT-17008-HK-AX	Tecnocom	Línea Jumbo		3,30	Tándem Graduable	Agujas Protección Anticorrosiva Rodadura Inox	Acero 304 Inoxidable	100	400
								Con Topes de 39,1 mm	

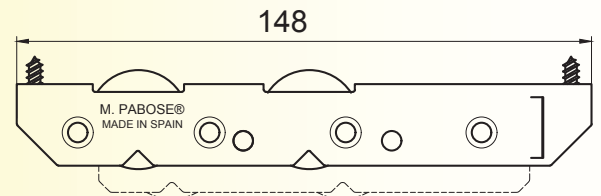
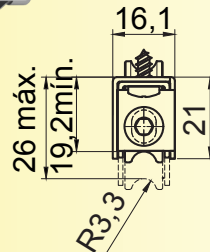
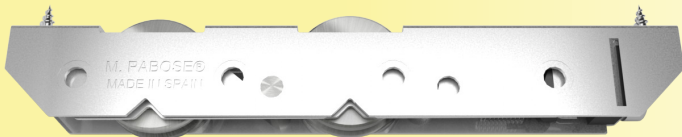

Para otras series al conjunto se le puede añadir topes de medidas comprendidas entre 10,5 y 39,1 mm para aumentar la altura en los casos que sea necesario. (Suministrados en Bolsa a parte)

“Los tornillos de fijación se suministran en bolsa aparte”

M. Pabose® como fabricante del producto se reserva el derecho de efectuar sin previo aviso, las modificaciones que considere oportunas para mejorar las prestaciones de sus productos.

Referencia	Extrusor/Cliente	Serie	Perfil	Rueda radio/ang.	Tipo de Conjunto	Rodamiento	Soporte	Carga (Kg)	
								Rueda	Hoja
TT4-15005-A		Varias		2,50	Fijo 4 ruedas	Agujas	Acero 304 Inoxidable	40	320

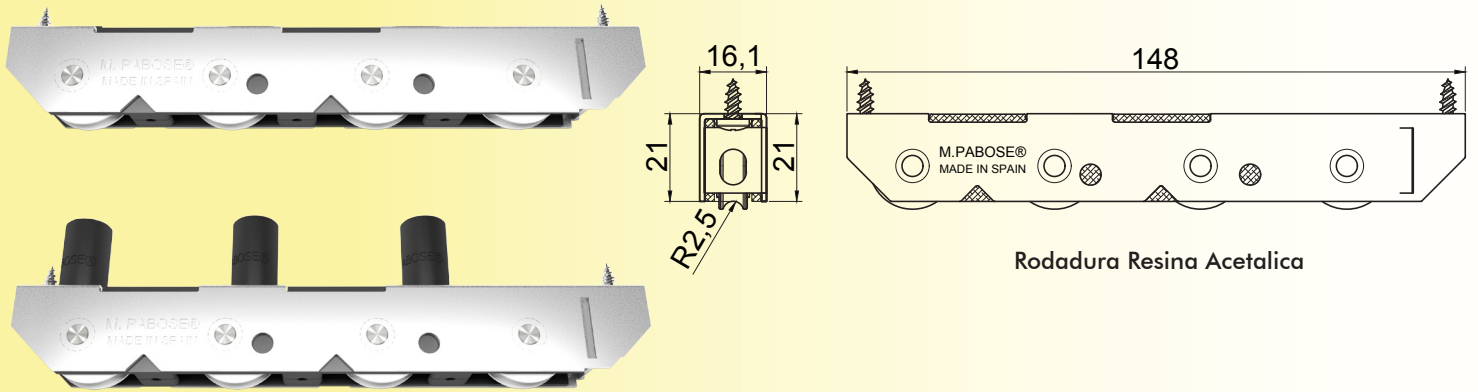

TT4-17022-A		Varias		3	Fijo 4 ruedas	Agujas	Acero 304 Inoxidable	50	400
--------------------	--	--------	--	---	---------------	--------	-------------------------	----	-----

TT4-17022-HK-A Casquillo de Agujas Protección Anticorrosiva

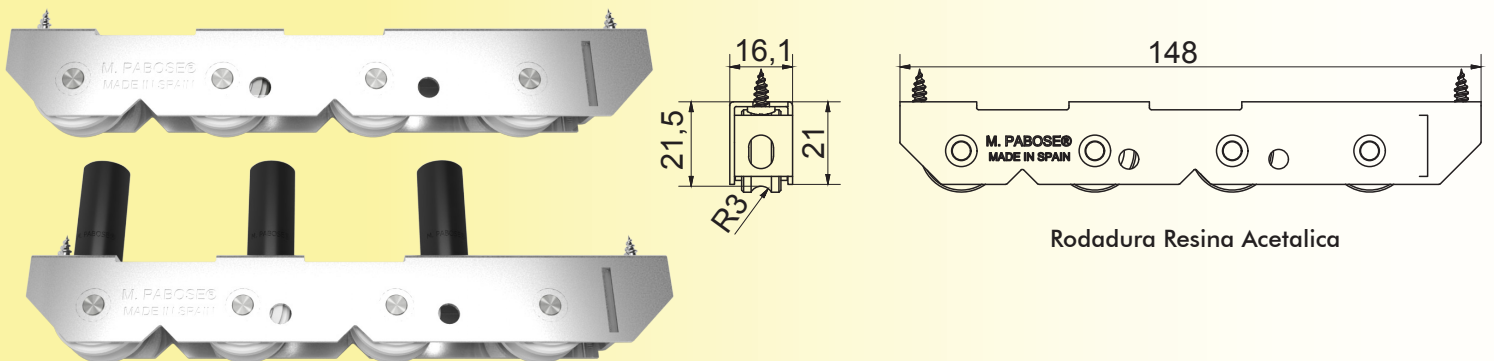

TT4-17022-AX		Varias		3	Fijo 4 ruedas	Agujas Rodadura Inox.	Acero 304 Inoxidable	80	640
---------------------	--	--------	--	---	---------------	-----------------------------	-------------------------	----	-----

TT4-17022-HK-AX Casquillo de Agujas Protección Anticorrosiva

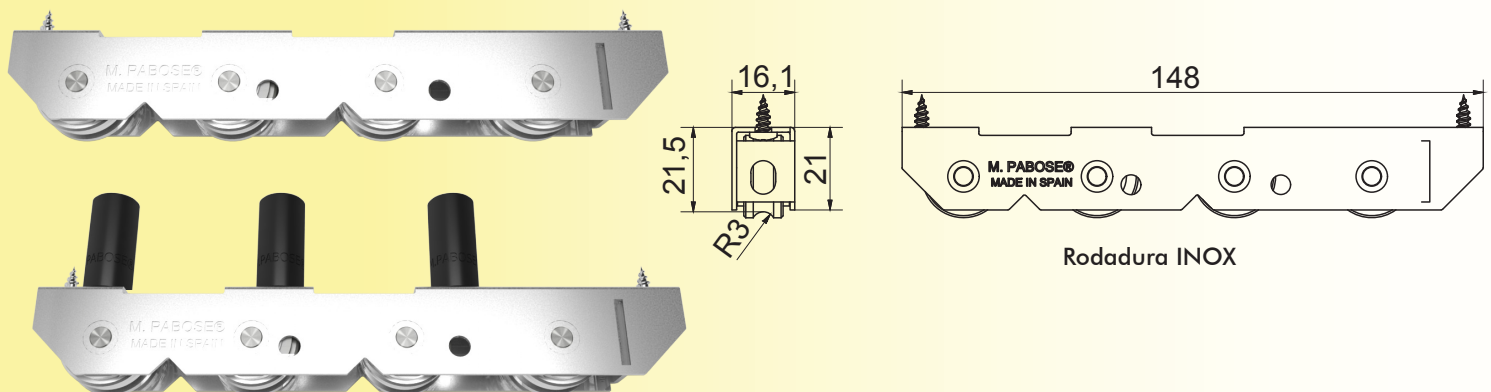

"Los tornillos de fijación se suministran en bolsa aparte"

IMPORTANTE: Al conjunto se les puede añadir topes fijados en la parte superior del soporte, de medidas comprendidas entre 10,5 y 39,1 mm, para aumentar la altura en los casos que sean necesarios

Referencia	Extrusor/Cliente	Serie	Perfil	Rueda radio/ang.	Tipo de Conjunto	Rodamiento	Soporte	Carga (Kg)	
								Rueda	Hoja
TT4-15003-XX		Varias		Pista Plana 6	Fijo 4 ruedas	Bolas Inox. Semicorrosivo	Acero 304 Inoxidable	62,5	500

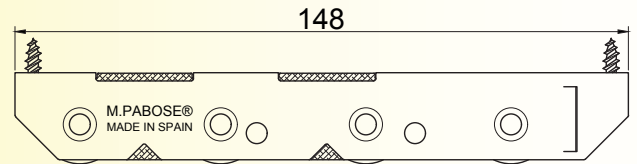
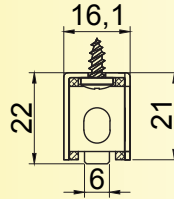
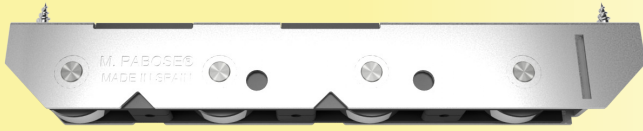

Rodadura INOX

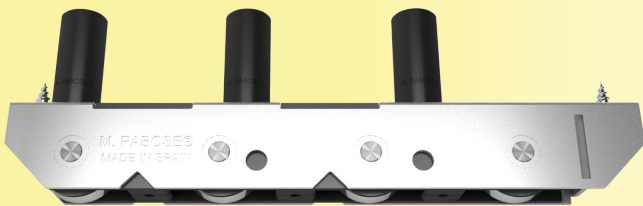

TT4-15027-HK-A		Varias		Pista Plana 6,8	Fijo 4 ruedas	Agujas Protección Anticorrosiva	Acero 304 Inoxidable	40	320
-----------------------	--	--------	--	-----------------------	---------------	---------------------------------------	-------------------------	----	-----

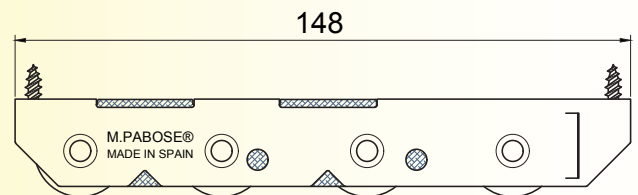
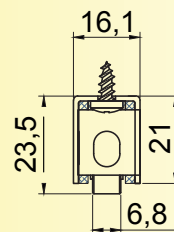

Rodadura Resina Acetalica



"Los tornillos de fijación se suministran en bolsa aparte"

IMPORTANTE: A los conjuntos de dos y tres ruedas, se les puede añadir dos topos fijados en los traladros de la parte superior del soporte, de medidas comprendidas entre 10,5 y 39,1 mm, para aumentar la altura en los casos que sean necesarios

1° Con broca de Ø 12 taladrar el perfil, utilizando el regle plantilla

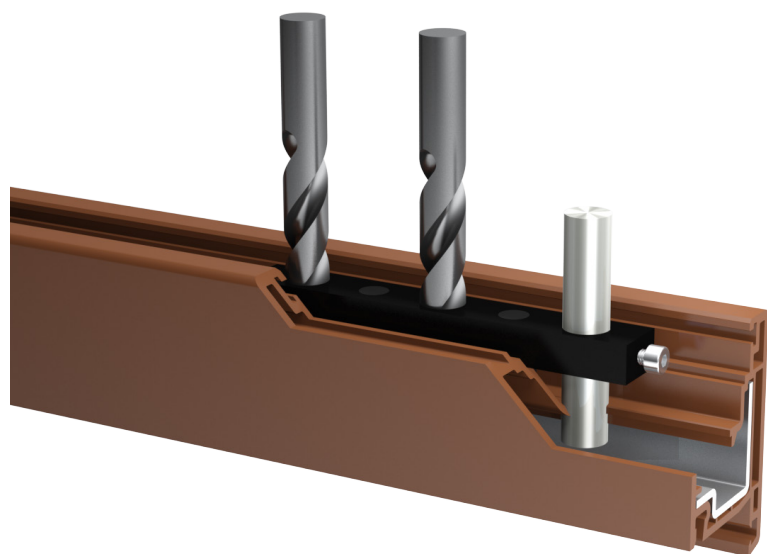
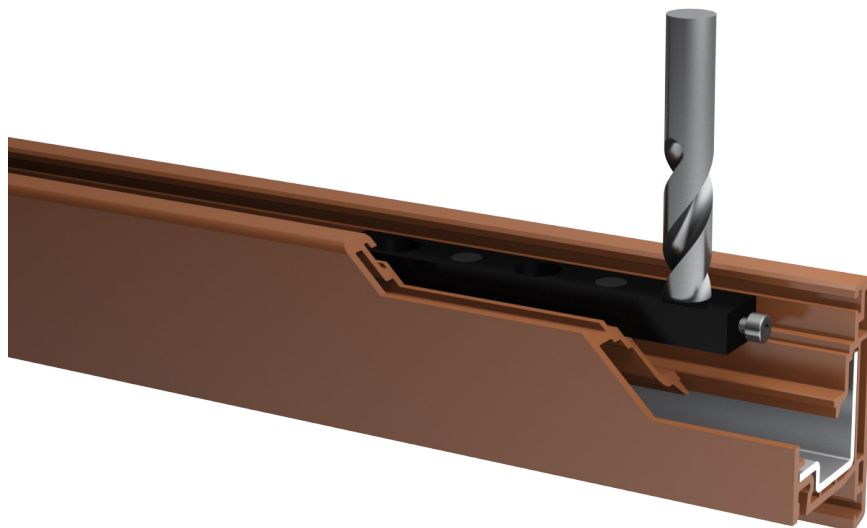

2° Montar el centrador cilindrico en el regle plantilla, introducirlo en el perfil y hacer los dos taladros restantes



Referencia	Descripción
PLNGT100404	Plantilla Montaje Cjto. Graduable Tándem 12 y Cjto. Fijo Simple 12 (Distancia entre taladros 35 mm)
PLNGTT15001	Plantilla Montaje Cjto. Graduable Tándem 16 (Distancia entre taladros 42 mm)

1° Con broca de Ø 12 taladrar el perfil, utilizando el regle plantilla

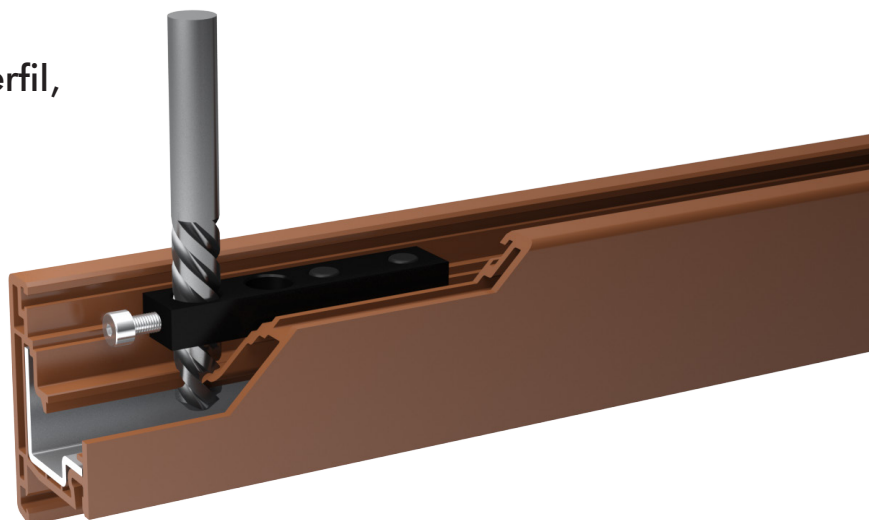

2° Montar el centrador cilindrico en el regle plantilla, introducirlo en el perfil y hacer los dos taladros restantes

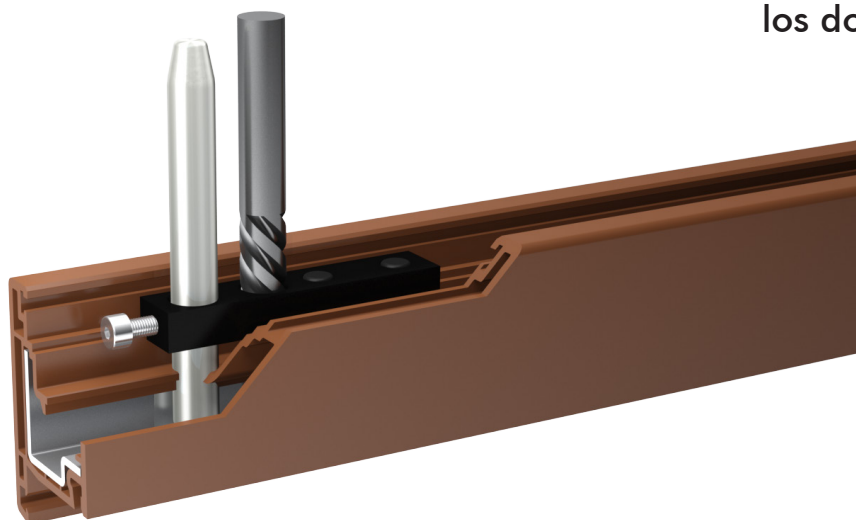

Referencia	Descripción
PLNTT15023	Plantilla Montaje Cjto.Fijo Tándem (Distancia entre taladros 20,5 mm)

Tope Poliamida	Tope Altura (mm)
	10,5 mm
	13,0 mm
	14,1 mm
	16,5 mm
	17,0 mm
	18,0 mm
	19,0 mm
	20,0 mm
	21,1 mm
	22,1mm
	23,2 mm
	24,0 mm
	25,0 mm
	26,3 mm
	27,8 mm
28,8 mm	
30,3 mm	
33,2mm	
39,1 mm	

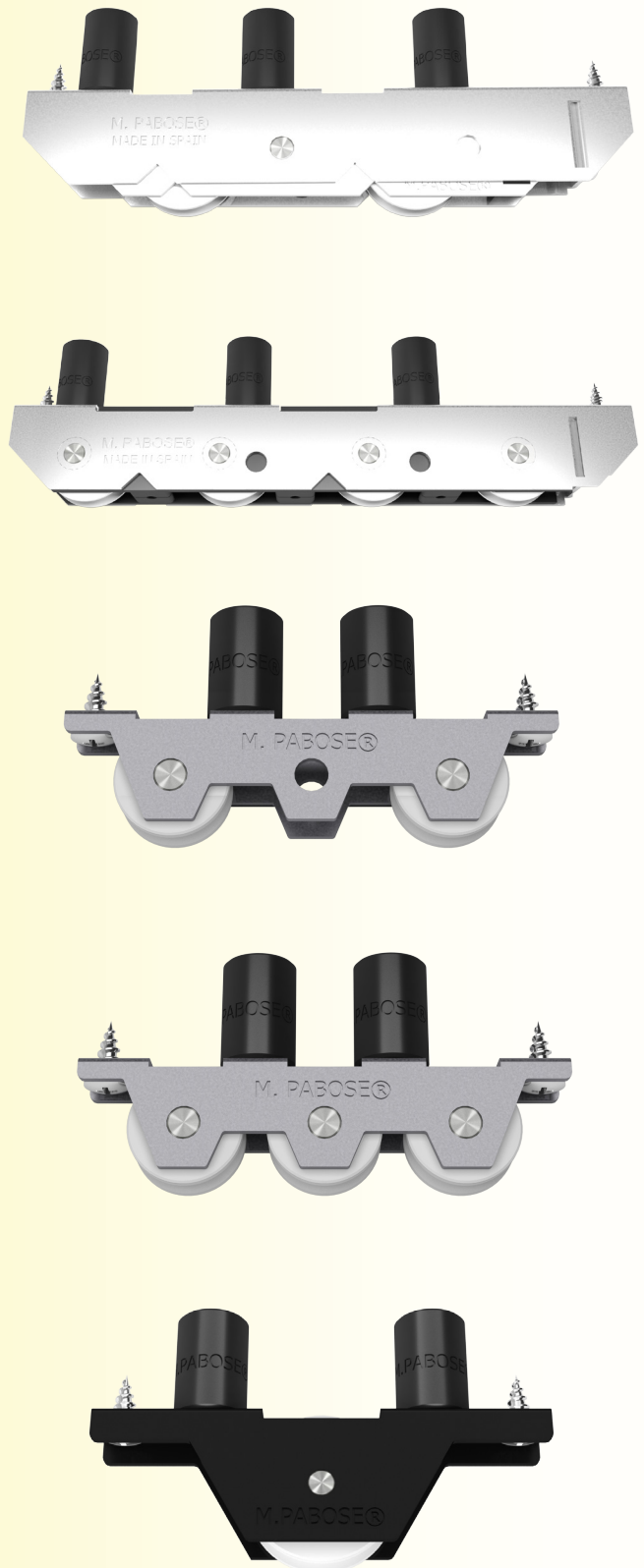

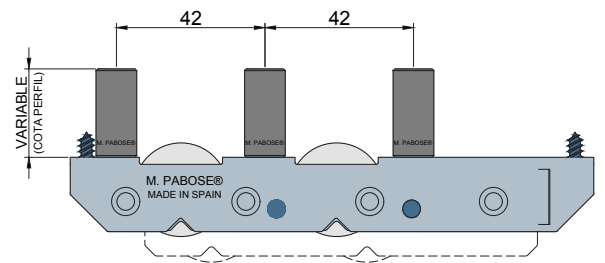
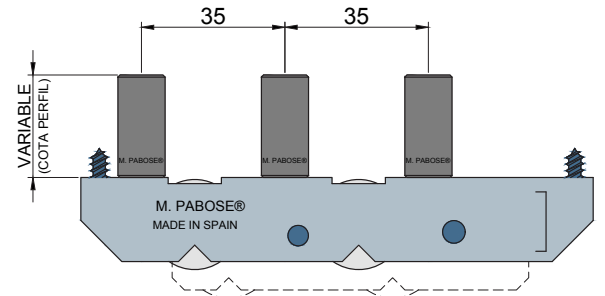
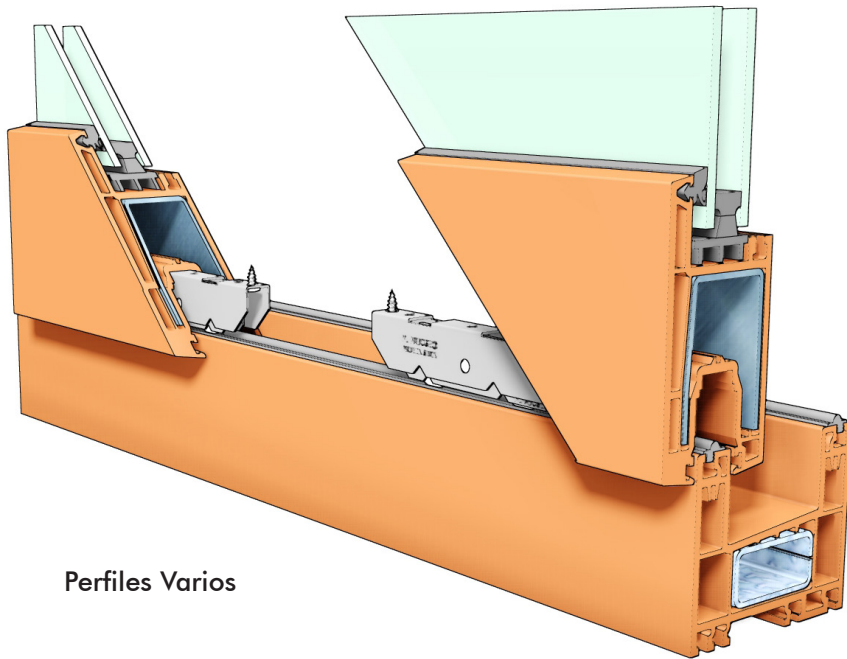
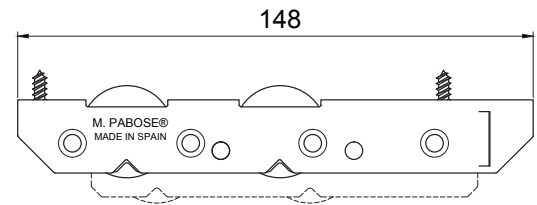
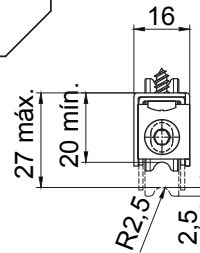
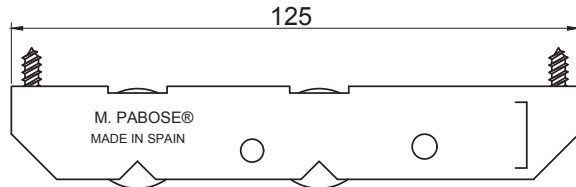
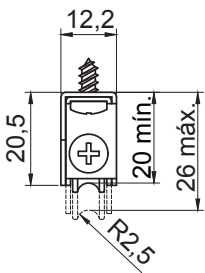

Perfiles Varios

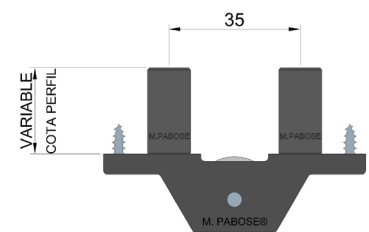
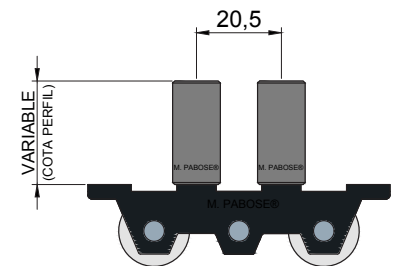
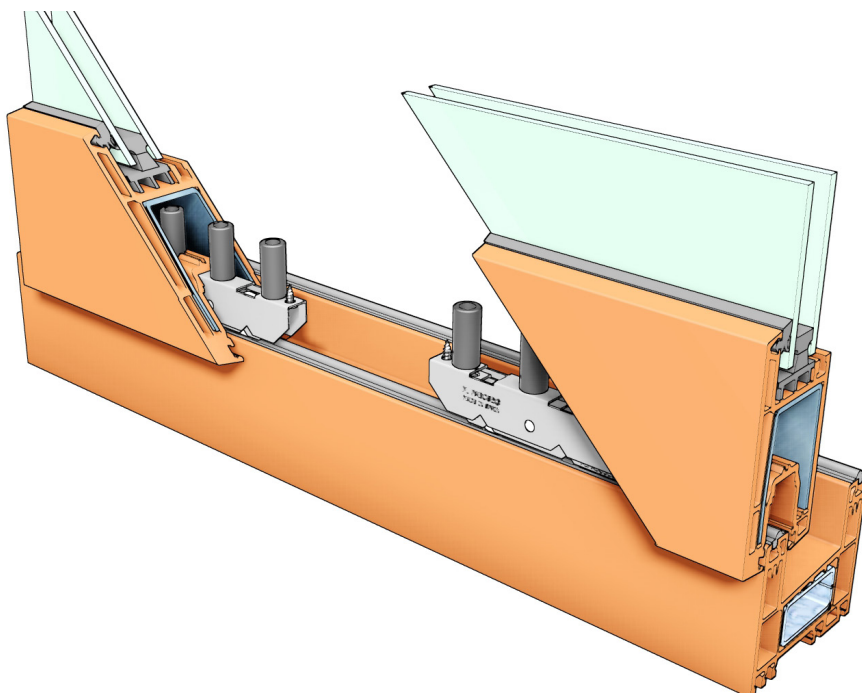

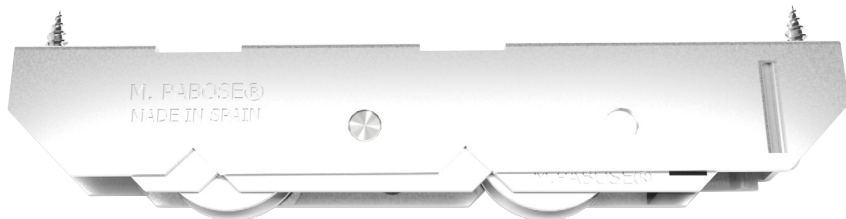
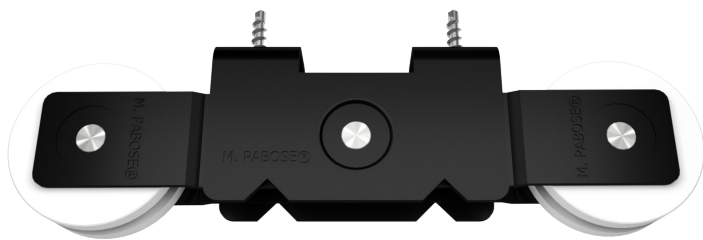

Octubre 2019



PRESENCIA

Gran presencia internacional en más de 30 países de todo el mundo.



CALIDAD

La calidad, la tecnología y el diseño de nuestros productos nos convierte en el punto de referencia del sector.



GAMA DE PRODUCTOS

Amplia gama de productos M.Pabose® reconocidos por el alto nivel de prestaciones.



SOLUCIONES PERSONALIZADAS

Si no encuentra el producto que necesita, contacte con nosotros y nuestro equipo le asesorará debidamente y le solucionará sus dudas.



WEB

Visite nuestra página web **www.pabose.com**



+ 34 93 691 79 11



info@pabose.com



www.pabose.com

C / Molí, 8-A
08291 Ripollt (Barcelona) SPAIN

